



Futurecom Systems Group, ULC

VRX1000
Functional Description

NOTES

Contents

| | |
|--|----------|
| Contents | 3 |
| List of Tables..... | 6 |
| List of Figures..... | 6 |
| Manual Revisions | 7 |
| Computer Software Copyrights..... | 7 |
| Disclaimer | 7 |
| Trademarks | 7 |
| Introduction | 8 |
| Firmware | 8 |
| VRX1000 Compatibility..... | 9 |
| VRX1000 Models | 10 |
| Frequency Band of Operation..... | 10 |
| Cross-Band | 10 |
| In-Band..... | 11 |
| Band Locking | 12 |
| VRX1000 Features Supported on Motorola Infrastructure | 13 |
| 'DVRS/VRX1000 Enabled' PSUs | 14 |
| 'VRX1000 Enabled' PSU Features Supported on Non-Motorola Infrastructure..... | 15 |
| VRX1000 Status Display..... | 16 |
| 'DVRS/VRX Enabled' Mobile Radio TGs / Channels | 16 |
| 'DVRS/ VRX Disabled' Mobile Radio TGs / Channels..... | 17 |
| Activating the VRX1000 via the MSU Control Head..... | 17 |
| Automatic VR Activation (AVRA) | 17 |
| Remote Activation of the VRX1000 | 18 |
| VRX1000 Modes of Operation | 20 |
| OFF Mode..... | 21 |
| SYSTEM Mode | 21 |
| LOCAL Mode | 22 |
| Selecting VRX1000 Mode and Channel | 23 |
| In Car Monitor (ICM)..... | 24 |
| Primary / Secondary Operation Basics | 25 |
| Permanent Primary Activation | 27 |
| Permanent Primary Deactivation | 27 |
| Legacy Mobexcom II Voting Compatibility Mode..... | 27 |
| VRX1000 Voting Compatibility Modes..... | 27 |
| MSU Scan | 28 |
| Supported MSU Scan Types | 28 |
| VRX1000 Enabled / Disabled Rules while MSU Scan is enabled..... | 28 |
| Outbound Calls (received by MSU from the FNE) with MSU Scan Enabled..... | 28 |
| Inbound Calls (received by VRX1000 from PSU) with MSU Scan Enabled..... | 28 |
| MSU ISSI Roaming | 29 |

| | |
|---|-----------|
| Unsupported Features..... | 29 |
| P25 Digital Mode Operation..... | 31 |
| PSU Affiliation | 32 |
| Group Calls | 32 |
| MSU Priorities | 32 |
| PSU Proxy Request Priorities..... | 32 |
| MSU Voice and Signaling Proxy Interactions..... | 33 |
| Talk Group Proxing | 33 |
| Talk Group Translation..... | 33 |
| Private Calls | 34 |
| PSU Talk Permit Tones..... | 34 |
| Status Broadcast..... | 35 |
| Local Mode Indication..... | 35 |
| Radio Check / Inhibit | 35 |
| P25 Trunking OTAR | 35 |
| Patch..... | 36 |
| Dynamic Regrouping..... | 37 |
| Phone Interconnect | 37 |
| Adaptive Power Control..... | 37 |
| Digital Audio Buffering..... | 37 |
| P25 Encryption..... | 38 |
| Remote VRX1000 Activation and Steering by PSU Call Alert (Page) | 39 |
| Emergency in Digital Mode..... | 41 |
| Emergency Alarm | 41 |
| Emergency Call..... | 42 |
| Emergency Revert through VRX1000 | 42 |
| Emergency Revert through PSU | 42 |
| Emergency operation during TG Translation..... | 42 |
| Fireground (FG) Signaling | 43 |
| PSU IV&D | 43 |
| PSU Location Reporting | 43 |
| PSU Call Alert | 43 |
| PSU Message | 43 |
| PSU Status Update and Status Request | 43 |
| Automatic PSU Revert to Talk Around (TA)..... | 43 |
| PSU Group Services | 44 |

| | |
|--|-----------|
| Group Text | 44 |
| Group Alias Update..... | 45 |
| Digital Mode – P25 Conventional Support | 46 |
| P25 Digital VRX1000 Mode with P25 Conventional Mode Selected on MSU..... | 46 |
| P25 Digital VRX1000 Mode (Generic P25 PSUs) with P25 Trunked (FDMA) Mode Selected on MSU | 47 |
| Digital Mode – P25 Enhanced Trunking Features Support | 48 |
| P25 Digital VRX1000 Mode with P25 Conventional Mode Selected on MSU..... | 48 |
| P25 Digital VRX1000 Mode with P25 Trunked (FDMA) Mode Selected on MSU | 49 |
| Forced Analog Mode..... | 50 |
| Forced Analog All DVR Mode- Operation and Programming Overview | 50 |
| Forced Analog Mode – Summary of Features | 51 |
| Forced Analog VRX1000 Mode with P25 Trunking TDMA Mode Selected on MSU..... | 51 |
| Forced Analog VRX1000 Mode with 3600 Trunking Mode Selected on MSU | 52 |
| Forced Analog VRX1000 Mode with Conventional Analog Mode Selected on MSU | 52 |
| Analog Mode Operation..... | 54 |
| VRX1000 Channel Setup for Analog Mode..... | 54 |
| Group Calls | 54 |
| Emergency in Analog Mode..... | 55 |
| Emergency Alarm | 55 |
| Emergency Call..... | 55 |
| Emergency Revert | 56 |
| Analog Audio Buffering..... | 56 |
| Tactical Public Safety (TPS)..... | 56 |
| Fireground (FG) Signaling | 56 |
| Remote VRX1000 Activation via DTMF | 57 |
| P25 Encryption in Analog Mode | 57 |
| Leading & Trailing Tones..... | 57 |
| Mobile Mode Steering via PL/DPL..... | 58 |
| Steering and Emergency | 58 |
| MSU Operating on TDMA (P25, Phase 2) | 58 |
| Analog Mode – Summary of Features | 59 |
| Analog VRX1000 Mode with P25 Trunking Mode (FDMA) Selected on MSU | 59 |
| Analog VRX1000 Mode with P25 Conventional Mode Selected on MSU | 60 |
| Analog VRX1000 Mode with Conventional Analog Mode Selected on MSU | 61 |
| Analog VRX1000 Mode with 3600 Baud Analog or Digital Trunking Mode Selected on MSU | 62 |
| Analog VRX1000 Mode with P25 Phase II (TDMA) Trunking Mode Selected on MSU | 63 |
| Mixed VRX1000 Mode | 64 |
| Special Features Support | 65 |

| | |
|----------------------------------|-----------|
| TPS Signaling | 65 |
| Contact Information | 66 |
| Glossary..... | 69 |
| Index | 72 |

List of Tables

| | |
|---|----|
| Table 1 VRX1000 Compatible MSUs | 9 |
| Table 2 VRX1000 vs Infrastructure Compatibility | 9 |
| Table 3 VRX1000 Features vs Type of PSU | 13 |
| Table 4 DVRS/VRX1000 Enabled PSU Models..... | 14 |
| Table 5 'VRX1000 Enabled' PSU Features Supported on Non-Motorola Infrastructure . | 15 |
| Table 6 OFF Mode Operation..... | 21 |
| Table 7 SYSTEM Mode Operation | 21 |
| Table 8 LOCAL Mode Operation | 22 |
| Table 9 Primary VRX1000 Definitions | 26 |
| Table 10 VRX1000 Voting Compatibility..... | 27 |
| Table 11 MSU Priorities | 32 |
| Table 12 PSU Proxy Request Priorities | 32 |
| Table 13 Inbound P25 Encryption Rules | 38 |
| Table 14 Outbound P25 Encryption Rules..... | 38 |
| Table 15 MSU MIC PTT P25 Encryption Rules | 38 |
| Table 16 Typical Remote Steering Scenarios..... | 40 |

List of Figures

| | |
|---|----|
| Figure 1 Cross-Band VRX1000 - Conceptual Diagram..... | 10 |
| Figure 2 In-Band VRX1000 - Conceptual Diagram | 11 |

Manual Revisions

| Rev # | Date | By | Notes & References |
|-------|-------------------|--------|--|
| 0 | November 11, 2014 | KG | Original Release |
| 1 | November 20, 2014 | KG | Updated MIL-STD-810G |
| 2 | July 22, 2015 | KG | Firmware R1.20/SR7.15.5 Update |
| 3 | October 15, 2015 | KG | Firmware R1.21/Q4 SER 2015 Update |
| 4 | February 11, 2016 | KG | Firmware R1.22/Q1 SER 2016 Update |
| 5 | October 12, 2016 | SN | Firmware R1.30/ SR7.17 Update |
| 6 | October 19,2016 | SN | Removed CH Firmware version. Updated VRX10000 features for MSU mode tables |
| 7 | April 17, 2017 | AJK/SN | Firmware R1.40/ SR7.17.5 update |
| 8 | May 1, 2017 | AJK/SN | Updated APX8500 Firmware version |
| | | | |
| | | | |
| | | | |

Computer Software Copyrights

The products described in this manual include copyrighted Futurecom computer programs stored in semiconductor memories or other media. Laws in the United States, Canada and other countries preserve for Futurecom certain exclusive rights for copyrighted computer programs, including but not limited to, the exclusive right to copy or reproduce in any form the copyrighted computer programs. Any copyrighted computer program contained in the Futurecom products described in this manual may not be copied, reproduced, modified, reverse-engineered, or distributed in any manner without the express written permission of Futurecom. The purchase of Futurecom products shall not be deemed to grant either directly or by implication, estoppels, or otherwise, any license under the copyrights, patents or patent applications of Futurecom, except for the normal non-exclusive license to use that arises by operation of law in the sale of a product.

Disclaimer

The information in this document is carefully examined and is believed to be entirely reliable. However, no responsibility is assumed for inaccuracies. Futurecom Systems Group, ULC. reserves the right to make changes to any products herein to improve reliability, function or design. Futurecom does not assume any liability arising out of the application or use of any product or circuit described herein.

Trademarks

MOTOROLA SOLUTIONS, ASTRO, XTL™2500, XTL™5000, XTS™1500, XTS™2500, XTS™5000, APX™2000, APX™4000, APX™6000, APX™7000, APX™8000, APX™6500, APX™7500, APX™8500 MDC1200 are trademarks of Motorola Solutions Inc.

Introduction

The VRX1000 is a simplex radio coverage extender, which is interfaced to a compatible remote mount Motorola Solutions Mobile Radio (see **Table 1**) and enables Portable Subscriber Units (PSUs) to be used in areas where only Mobile Subscriber Unit (MSU) coverage is available and PSU coverage is either intermittent or completely absent.

Installed in the trunk of a car, fire truck, armored vehicle, ambulance, the VRX1000 extends radio communications to the PSU users who are outside of the vehicle, inside a nearby building or in any marginal portable radio coverage areas. The VRX1000 extends voice (analog, P25 clear or P25 encrypted) communications and supports key trunking system features. The VRX1000 can be configured to provide various advanced options to the users.

Unlike the Digital Vehicular Repeater System (DVRS), which can be configured for either simplex or full duplex operation, the VRX1000 supports only simplex mode and can't extend local PSU-to-PSU communications. When using the VRX1000, the Local PSUs communicate with each other in Talk Around (TA) mode and with the System users via the VRX1000.

The DVRS is required in applications where local radio coverage extension is needed (between the Local PSUs) in addition to the System-to-Local PSU and Local PSU-to-System coverage extension.

This document only describes the VRX1000 operation.

Firmware

The VRX1000 Operation described in this Document requires the following Firmware:

APX5500/APX6500/APX7500- firmware release: **Host R16.00.00 or later.**

APX8500 - firmware release: **Host R16.01.00 or later.**

APX Mobile Radios operating as the host mobile for the VRX1000 require subscriber option **GA00631** for operation.

APX2000/APX4000/APX6000/APX7000/APX8000 – firmware release **R15.00.00 or later.**

APX Portable Radios operating through a DVR/VRX1000, utilizing the DVR/VRX1000 Enabled digital feature set require subscriber option **QA00631**.

APX Control Head - firmware release **R20.00.00 or later.**

VRX1000 must be loaded with application firmware **4C083X11 R01.40 or later.**

Tweaker Programming software version **1.14 or later.**

VRX1000 Compatibility

The Vehicular Radio Extender (**VRX1000**) is designed to be seamlessly interfaced to the following Motorola Solutions Mobile Radios:

| Mobile Radio Model | Firmware Requirements | Notes |
|---|-----------------------|--------------------------------|
| APX5500 | R16.00.00 or later | Requires option GA00631 |
| APX6500 | R16.00.00 or later | |
| APX7500 | R16.00.00 or later | |
| APX8500 | R16.01.00 or later | |
| NOTE: Mobile Radio must be configured as Remote Mount in order to be compatible with the VRX1000. | | |

Table 1 VRX1000 Compatible MSUs

The VRX1000 is a simplex radio coverage extender, which is interfaced to a compatible remote mount Motorola Solutions Mobile Radio and enables Portable Subscriber Units (PSU) to be used in areas where only Mobile Subscriber Unit (MSU) coverage is available and PSU coverage is either intermittent or completely absent. Installed in the trunk of a car, fire truck, armored vehicle, ambulance, the VRX1000 extends radio communications to the PSU users who are outside of the vehicle, inside a nearby building or in any marginal portable radio coverage areas. The VRX1000 extends voice (analog, digital clear or digital encrypted) communications and supports key trunking system features. The VRX1000 can be configured to provide various advanced options to the users.

Table 2 provides information on the VRX1000 infrastructure compatibility options.

| FIXED NETWORK TYPE / MOBILE RADIO MODE | | | | | |
|--|---|--------------------------------------|--------------------------------|------------------------|------------------------|
| Portable Radio Type / Mode | Conventional Analog incl. Mixed Receive | Conventional P25 incl. Mixed Receive | 3600 Analog / Digital Trunking | 9600 P25 Trunking FDMA | 9600 P25 Trunking TDMA |
| Conventional Analog | YES A | YES A/M | YES A | YES A/M | YES A |
| Generic P25 Conventional | NO | YES D/FA/M | NO | YES D/M | NO |
| P25 Conventional 'DVRS Enabled' | YES FA/FA-All | YES D/FA/FA-All/M | YES FA/FA-All | YES D/FA/FA-All/M | YES D/FA/FA-All/M |

Table 2 VRX1000 vs Infrastructure Compatibility

VRX Channel Types:

A = Analog, D = Digital, M = Mixed, FA = Forced Analog, FA-All=Forced Analog All
(See Part II of this manual)

VRX1000 Models

Frequency Band of Operation

Depending on the frequency band of operation of the APX Mobile Subscriber Unit (MSU) and VRX1000, the VRX1000 models are classified as follows:

- **In-Band** – when the MSU and VRX1000 operate in the same frequency band.
- **Cross-Band** – when the MSU and VRX1000 operate in two different frequency bands.

Cross-Band

Cross-Band VRX1000 models do not include any filters on the MSU side since the MSU and VRX1000 are not intended to simultaneously operate in the same frequency band. In single band MSU configurations the MSU and VRX1000 operate in different frequency bands.

In dual band MSU configuration either the MSU & VRX1000 operate in 3 different frequency bands or one of the MSU frequency bands is locked out when VRX operation is enabled as shown on **Figure 1**.

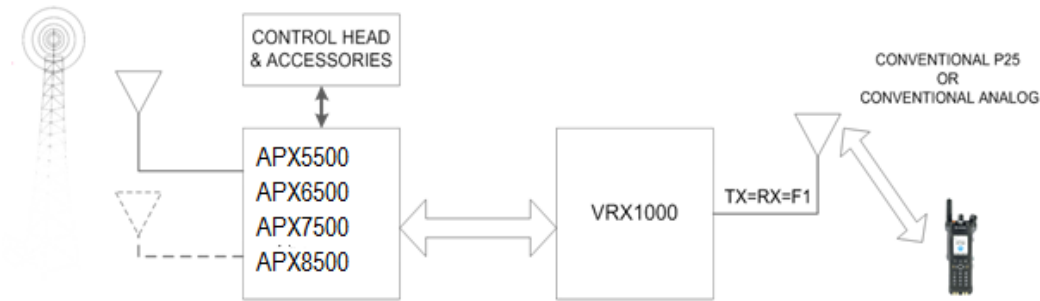

Figure 1 Cross-Band VRX1000 - Conceptual Diagram

In-Band

The in-band VRX1000 models are equipped with two sets of filters, which are required in order to ensure interference-free operation when both the MSU and VRX1000 are transmitting and receiving simultaneously in the same frequency band. The VRX1000 filter provides 40 dB isolation on the Mobile radio transmit / receive frequencies. The filter installed at the output of the MSU is designed to provide 40dB isolation on the VRX1000 TX/RX Frequency Range.

IMPORTANT!

The above filter isolation must be complemented by 30dB minimum antenna isolation (between the VRX1000 and Mobile Radio antennas) in order to ensure interference-free operation. It is recommended that the MSU in-band antenna is mounted on the roof top of the vehicle while the VRX antenna is mounted on the trunk. Each VRX1000 is shipped equipped with custom filters tuned to the specified frequency bands – note the frequency range specified on the filter labels. Programming the VRX / MSU radio to operate on frequencies outside of the original specified bands may result in intermittent or complete loss of communications. Frequency changes may require filter retuning or replacement.

NOTE:

The VRX1000 and MSU require two or three (in the case of dual band MSU) separate antennas.

NOTE:

The In-Band filters connected to the APX MSU are rated for maximum 50 Watts Tx power and have typical insertion loss of 1.5dB.

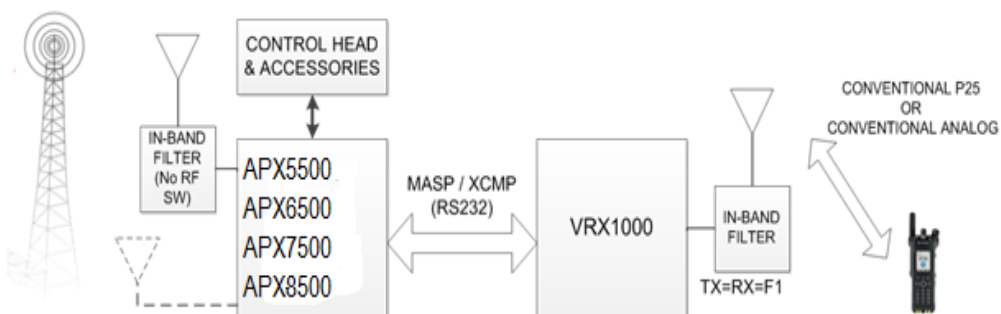

Figure 2 In-Band VRX1000 - Conceptual Diagram

Band Locking

Two in-band sets of filters – one placed at the MSU Antenna port and another placed at the VRX1000 Antenna port are required when both the MSU and VRX1000 are configured to operate in the same frequency band. The frequency specific in-band filters are required in order to prevent interference when the VRX1000 is receiving & MSU is transmitting and vice versa.

When the in-band filter is not present, the Band Lock feature must be enabled (by using the Tweaker programming software) in order to prevent VRX1000 operation on MSU channels that are explicitly using the same frequency band as the VRX1000. On MSU channels where the frequency band is not explicitly known such as in multi-site trunking systems, the MSU will be prevented from using frequencies in the same band while the VRX1000 is active (i.e. in SYSTEM or LOCAL mode). In this case the MSU will no longer allow roaming to sites using the locked out band. If the MSU is currently on a trunking site that uses the locked out band, the MSU will roam to another site. If no other sites are available, the MSU will enter Out Of Range state. When the VRX1000 is inactive (OFF mode), the MSU frequency band is unlocked.

In the case of a single band MSU (such as the APX4500 and APX6500), in-band VRX1000 applications always require in-band filters and the Band Locking feature must be disabled. For MSU conventional channels where the band is known and fixed, the VRX1000 restricts access to channels using the locked out frequency band.

If Band locking is enabled in the VRX1000 and SCAN is enabled in the MSU, the MSU will skip over any channels in the scan list that are configured to operate in the same frequency band as the VRX1000.

IMPORTANT!

A 700MHz VRX1000 interfaced to an APX MSU operating on 800MHz as well as an 800MHz VRX1000 interfaced to an APX MSU operating on 700MHz are considered In-Band applications and either In-Band filters must be provided or band locking must be enabled (if the MSU is dual band and VRX operation can be supported on the non 700/800MHz band).

The above is also valid for any of the UHF Bands – if the MSU operates on any of the UHF ranges, an UHF VRX interfaced to it will require in-band filters to be installed or band locking to be enabled.

VRX1000 Features Supported on Motorola Infrastructure

When the PSU user is out of system radio coverage, the PSU can be switched to a dedicated VRX1000 channel so that the PSU can communicate via the VRX1000. The features available to the PSU user depend on the PSU type, programming and selected mode. The table below specifies what features are supported by the different PSU types.

| PSU FEATURE SUPPORT BY VRX1000 | DVRS/VRX Enabled PSU [Note 5] | Generic P25 PSU | Analog PSU |
|--|--------------------------------------|------------------------|-------------------|
| Registration / Deregistration | Yes | Yes [Note 1] | Yes [Note 3] |
| Talk Group Proxying / Translation | Yes | Yes | No |
| Group Calls | Yes | Yes | Yes |
| Private Calls | Yes | No | No |
| Announcement Group | No | No | No |
| Phone Interconnect | No | No | No |
| Patch | Yes | No | No |
| Dynamic Regrouping | Yes | No | No |
| Selector Lock / Unlock | No | No | No |
| Emergency Call / Alarm | Yes | Yes | Yes |
| Emergency ID Pass through | Yes | Yes | Yes [Note 2] |
| PSU Hot Mic | Yes [Note 4] | No | No |
| PSU Emergency Revert | Yes | Yes | Yes |
| P25 Encryption | Yes | Yes | No |
| Call Alert Page | Yes | Yes | No |
| System Status Broadcast (Failsoft, Out Of Range, Site Trunking) | Yes | No | No |
| Local Mode Indication | Yes | No | No |
| Adaptive Power Control | Programmable | Yes [Note 6] | No |
| PSU Revert to Talk Around when no VRX1000 present | Yes | No | No |
| Talk Permit Tones (generated by PSU) | Yes | No | No |
| Leading / Trailing Tones (sent over the air) | No | No | Yes |
| Radio Check / Radio Inhibit | Yes | Yes | No |
| P25 Trunking OTAR | Yes | No | No |
| PSU GPS | Yes | No | No |
| PSU Group Services | Yes [Note 7] | No | No |
| PSU SCAN | No | No | No |
| Remote VRX Activation by PSU | Yes (Call Alert) | Yes (Call Alert) | Yes (DTMF) |
| Remote VRX Activation by PSU Emergency Alarm | Yes | Yes | Yes (MDC1200) |

Table 3 VRX1000 Features vs Type of PSU

Note 1 When selecting a VRX1000 Mode on the Generic P25 PSU, it registers upon first Group Call. Generic PSU is deregistered after a preprogrammed timer counting the period of inactivity expires.

Note 2 Supported only with MDC1200 capable portables. Emergency Alert ID Pass through only supported.

Note 3 Analog PSU is registered on the P25 system with its MDC1200 ID.

Note 4 Requires firmware R12.00.13 or later if using XTS and R07.00.05 or later if using APX 'DVRS/VRX Enabled' PSU.

Note 5 The PSU models that can be programmed as **DVRS/VRX Enabled** are described in **Table 4**.

Note 6: Motorola Solutions XTS or APX series PSUs in non DVRS/VRX Enabled mode.

Note 7: Group Services only supported on APX 'DVRs Enabled' PSUs (R14.50.00 or later in PSU/MSU).

'DVRs/VRX1000 Enabled' PSUs

The following Portable Radios have firmware that allows enhanced communications with the DVR / VRX1000 and support of an extended list of features.

| PSU Models that can be 'VRX1000/DVRs Enabled' | PSU Firmware Revision Required |
|---|--|
| XTS1500 XTS2500 XTS5000 | R9.00.00 and higher <i>Note: It is highly recommended to always use the latest released PSU firmware to ensure all fixes and new features are included.</i> |
| APX4000 APX6000 APX7000 APX8000 | R7.00.05 and higher APX8000 - R14.50.00 and higher <i>Note: It is highly recommended to always use the latest released PSU firmware to ensure all fixes and new features are included.</i> APX portable radios operating through a DVR, utilizing the enhanced DVR digital feature set require subscriber option QA00631 . |

Table 4 DVRs/VRX1000 Enabled PSU Models

All other P25 capable PSU models or the above models with either older firmware versions or when not programmed as 'DVRs/VRX Enabled', can only be programmed as 'P25 Generic' since they are not capable of enhanced communications with the VRX1000.

IMPORTANT!

The VRX1000 must have Option TT05953AA in order to be able to use with VRX/DVRs Enabled portable radios.

'VRX1000 Enabled' PSU Features Supported on Non-Motorola Infrastructure

| 'VRX1000 ENABLED' PSU FEATURE SUPPORT | HARRIS P25 Trunked FDMA | CASSIDIAN P25 Trunked FDMA |
|---|---|----------------------------|
| PSU Registration / Deregistration | Yes | Yes |
| PSU Talk Group Proxying / Translation | Yes | Yes |
| In Car Monitor | Yes | Yes |
| MSU MIC PTT with VRX1000 ON | Yes | Yes |
| PSU Group Calls | Yes | Yes |
| PSU Private Call II* | Yes | Yes |
| PSU Emergency Call / Alarm | Yes | Yes |
| PSU Emergency ID Pass Through | Yes | Yes |
| PSU Hot Mic | Yes | Yes |
| PSU P25 Encryption | Yes | Yes |
| PSU Call Alert Page | Yes | Yes |
| Out Of Range / Site Trunking indication on PSU | Yes | Yes |
| VRX1000 OOR indication on PSU | Yes | Yes |
| FNE NO COMMS indication through DVRS | Yes | Yes |
| VRX1000 Local Mode Indication on PSU | Yes | Yes |
| Talk Permit Tones (generated by PSU) | Yes | Yes |
| PSU Radio Check / Radio Inhibit | Yes | Yes |
| PSU P25 Trunking OTAR | Yes - Limited | Yes |
| PSU Adaptive Power Control | Yes | Yes |
| PSU Phone Interconnect | No | No |
| PSU Patch & Simulselect | Yes | Yes |
| PSU Dynamic Regrouping | Not Supported | Not Supported |
| PSU GPS | Yes | Yes |
| Remote VRX1000 Activation by PSU Call Alert Page to VRX1000 ID | Yes | Yes |
| Remote VRX1000 Activation by PSU Emergency Alarm Retries | Yes | Yes |
| PSU Status / Message | Yes | Yes |
| Remote MSU Channel Steering via PSU Call Alert Page to VRX1000 ID | Yes | Yes |
| Data | Not Supported | Not Supported |
| PSU OTAP | Not Supported | Not Supported |
| MSU Votescan | Not Supported | Not Supported |
| Limited Features support on P25 TDMA FNE | Yes (Group Voice, PTT-ID and Emerg Alarm/Call) | Not Supported |

Table 5 'VRX1000 Enabled' PSU Features Supported on Non-Motorola Infrastructure

*PC II support only; Enhanced Private Calls are only supported on Motorola infrastructure.

VRX1000 Operation and Basic Features

The operation of the VRX1000 is determined by the following:

- Firmware, Tier Options and programming settings of the VRX1000 (VRX1000 personality).
- Firmware options and programming settings of the MSU that is interfaced to the VRX1000.
- Configuration capabilities and programmed settings of the radio system.
- Type and programming settings of the portable radios used for communications through the VRX1000.

IMPORTANT!

Depending on the selected personality settings and configuration capabilities of the complete radio system infrastructure, the features / options described throughout this document may or may not be applicable to the specific VRX1000 operation.

VRX1000 Status Display

The VRX1000 Status is displayed on the MSU Control Head. The VRX1000 current mode and channel alias are displayed on the top line (for example VR SYS CHAN1) and a dedicated icon indicates if a VRX1000 is transmitting, receiving, is a Primary or a Non-Primary etc.

'DVRS/VRX Enabled' Mobile Radio TGs / Channels

VRX1000 operation may be enabled (by the VRX1000 and MSU programming) on selected mobile radio Talk Groups / channels and disabled on others.

When the user selects a DVRS/ VRX1000 Enabled TG / channel on the MSU control head, the VRX1000 operation is enabled in the following manner:

- The VRX1000 automatically enters the pre-programmed VRX1000 mode/channel associated ('Strapped') with the selected MSU TG / channel if VRX1000 strapping is programmed in the VRX1000.

OR

- The user may change the VRX1000 mode / channel (if 'strapping' is not enabled) by pressing the assigned **DVRS/VRX1000** button and entering the 'DVR/VRX1000 control mode'.
- The VRX1000 can be activated and used to repeat messages between the system users of the TG/channel selected on the MSU and the PSU users on the selected VRX1000 channel.
- If enabled in the VRX1000 personality, 'VRX1000 Enabled' tones will be heard every few seconds (5-255 sec. programmable) in the MSU speaker, regardless of the Primary / Secondary status.

'DVRs/ VRX Disabled' Mobile Radio TGs / Channels

VRX1000 operation may be enabled on selected mobile radio Talk Groups / channels and disabled on others.

When the user selects a "DVRs/VRX1000 Disabled" TG / channel on the control head:

- Pressing the DVRs/VRX1000 button results in a VRX1000 Invalid Option Tone (single low-pitched tone).
- VRX1000 operation is prohibited i.e. all VRX1000 functions are disabled.
- Call Alert Page from the local PSU, sent on the last used VRX1000 channel, can steer the MSU to a 'VR Enabled' mode if programmed accordingly.

Activating the VRX1000 via the MSU Control Head

The VRX1000 mode of operation and status can be changed from the 'DVRs' button as programmed in the APX MSU. The VRX1000 channel can be controlled by pressing the 'DVRs' button and subsequently pressing the up / down navigation keys to scroll through the available channel selection.

Automatic VR Activation (AVRA)

The VRX1000 can be activated automatically (switched from OFF or LOCAL to SYSTEM Mode) if one of the VIP inputs on the MSU control head is wired to the desired trigger source – portable charger switch or door switch or custom manual switch. When AVRA is enabled in the VRX1000, the user still has the option of manually changing the VRX1000 mode from the MSU Control Head or remotely.

IMPORTANT!

The VRX1000 can be activated via AVRA only if a 'DVR/VRX Enabled' TG / Channel is selected on the MSU.

Remote Activation of the VRX1000

Via Call Alert (Page) to VRX1000

NOTE:

This feature requires the use of a P25 PSU and implies Digital or Forced Analog VRX1000 Mode of operation.

To remotely activate a VRX1000, the PSU user can send a Call Alert (Page) with the ID of the specific VRX1000.

Upon receipt of a Call Alert (Page) from the PSU the VRX1000 will:

- Switch from OFF or LOCAL mode to SYSTEM mode (unless it is already in the SYSTEM mode). If the selected VRX1000 / MSU channel is programmed as LOCAL only, the VRX1000 will switch from OFF to LOCAL mode.
- Switch to Primary status and force any other Primary VRX1000 to become a Secondary unless there is a Permanent Primary (on the same VRX1000 channel) already present in the same area.
- Force the MSU to revert to a TG selected on the PSU (if programmed).

Via PSU Emergency Alarm

The VRX1000 switches from OFF to SYSTEM mode after a programmable number of Emergency Alarm attempts sent by a PSU are successfully received by the VRX1000 and are not serviced by another (Primary) VRX1000.

Via PSU DTMF Tones

To remotely activate a VRX1000 (analog mode), the PSU user can send a preprogrammed DTMF sequence, which can be received by VRX1000 in the PSU radio coverage area.

Upon receipt of the preprogrammed DTMF sequence from the PSU the VRX1000 will:

- Switch from OFF or LOCAL mode to SYSTEM mode.
- Switch to Primary status unless there is already a Primary / Permanent Primary VRX1000 (on the same VRX1000 channel) already present in the same area.

DTMF activation is supported on analog or mixed mode VRX1000 channels only.

Via System / Dispatcher Call Alert Page to MSU

Dispatcher can send a Call Alert (Page) to a specific MSU ID, which in turn causes VRX1000 mode change in the following order: OFF-SYS-LOC-OFF.

- The MSU can be programmed to support one of the following configurations:
- a. Call Alert / Remote Activation Disabled – the MSU does not respond to any Call Alert requests
 - b. Call Alert Enabled – the MSU responds to Call Alerts addressed to its ID and does NOT initiate VRX1000 mode change
 - c. Remote Activation Enabled – the MSU will acknowledge Call Alerts addressed to its ID and will initiate VRX1000 mode change provided the source ID of the Call Alert is programmed in the “VRX1000 Remote Activation IDs” table.

If “Generate Status on DVR Mode Change” is enabled for a given VRX1000 Profile (in the APX MSU) , the MSU will send back a mode change status to indicate the current VRX1000 mode (OFF, SYSTEM, LOCAL). Only the dispatcher console can interpret those status messages:

| DVR MODE | STATUS VALUE |
|----------|--------------|
| OFF | 1 |
| LOCAL | 2 |
| SYSTEM | 3 |

Dispatcher can't force a Non-Primary VRX1000 to become a Primary and can't activate a VRX1000 when a 'VR Disabled' mode is selected on the control head.

VRX1000 Modes of Operation

When a “DVR/VRX Enabled” TG / Channel is selected on the control head, the VRX1000 can be switched to one of the following modes – OFF, LOCAL or SYSTEM.

OFF mode is used when the VRX1000 repeat is not required (for example while the PSU user is in the vehicle driving).

LOCAL mode is used when the MSU operator in the car wants to talk only to the Local PSUs and communications with the FNE are not required (in case of tactical operations for instance).

SYSTEM mode enables VRX100 repeat of system calls to the local PSUs and vice versa. The System Calls are heard on the MSU speaker. The local PSU calls are also heard on the MSU speaker if In Car Monitor is enabled. If the MSU User keys up the MSU microphone, the call is only repeated by the MSU to the System. The VRX1000 does not key up.

OFF Mode

| ACTIVITY | OFF MODE ACTION |
|--|--|
| Control Head Display | VR OFF <VRX1000 CH Name> |
| 'DVRs' Button Press | Short high-pitched tone. Control Mode is accessible. |
| MSU Receiving from System | VRX1000 does not repeat audio received by MSU. MSU Speaker Audio present. |
| MSU User PTTs the MSU Microphone | MSU Keys up. VRX1000 does not key up. |
| PSU Activity on selected VRX1000 channel | No MSU repeat, no ICM. |

Table 6 OFF Mode Operation

SYSTEM Mode

| ACTIVITY | SYSTEM MODE ACTION |
|----------------------------------|--|
| Control Head Display | VR SYS <VRX CH Name> |
| VRX1000 Active Tones | If programmed, a short high-pitched 'VRX1000 Enabled' tone is repeated every few seconds (5-255 sec. programmable) in the MSU Speaker regardless of the Primary / Secondary Status of the VRX1000. |
| 'DVRs' Button Press | Short high-pitched tone. DVR Control Mode is accessible. |
| MSU User PTTs the MSU Microphone | MSU keys up. VRX1000 does not key up. |
| MSU Receiving from System | VRX1000 repeats audio received by MSU to PSU Users of the selected VRX1000 Channel. MSU Speaker Audio is present. |
| PSU Activity on VRX1000 channel | MSU repeats the PSU call to the System. MSU Speaker Audio is present if In-Car Monitor is enabled in the MSU. |

Table 7 SYSTEM Mode Operation

LOCAL Mode

| ACTIVITY | LOCAL MODE ACTION |
|----------------------------------|---|
| Control Head Display | VR LOC <VRX1000 CH Name> |
| VRX1000 Active Tones | If programmed, a short high-pitched 'VRX1000 Enabled' tone is repeated every few seconds (5-255 sec. programmable) in the MSU Speaker regardless of the Primary / Secondary Status of the DVR. |
| 'DVRs' Button Press | Short high-pitched tone. VRX1000 Control Mode is accessible. |
| MSU Receiving from System | VRX1000 may be programmed to repeat audio received by MSU to the PSU Users over the VRX1000 Channel. MSU Speaker Audio is present. |
| MSU User PTTs the MSU Microphone | MSU only or VRX only keys up as programmed [Note: The MSU and VRX programming must be correctly matched to allow either the MSU or the VRX to transmit when the MSU PTT Microphone is pressed as described in the VRX1000 Programming Guide in order to prevent undesired loss of communications. |
| PSU Activity on VRX1000 channel | MSU Speaker Audio is present if In-Car Monitor is enabled in the MSU. |

Table 8 LOCAL Mode Operation

NOTE:

Due to FCC Exposure licensing limitations, when the User PTTs the MSU Microphone, only one of the transmitters is allowed to be keyed up (VRX or MSU) as described in **Table 7** and **Table 8**.

Selecting VRX1000 Mode and Channel

When a 'DVR/VRX Enabled' TG / Channel is selected on the MSU, the user may enter the 'DVR/VRX Control Mode' by pressing the 'DVR' button on the control head and change the VRX1000 Mode / Channel if such selection is enabled by the VRX1000 programming.

The VRX1000 mode and channel may be programmed to be 'Strapped' to the specific MSU TG/Channel. In this case, selecting a specific MSU TG / Channel on the control head would automatically force the VRX1000 to revert to a pre-programmed VRX1000 Mode and/or Channel. *For example, selecting a DVR/VRX Enabled TG named 'DISPATCH' on the MSU may automatically force the VRX1000 to switch to VR Channel 1, SYSTEM Mode.*

NOTE:

Depending on the specific VRX1000 personality programming, the VRX channel selection may be restricted to a short list of allowed VRX channels (or no channel selection options at all). If Channel Strapping is enabled then the VRX1000 will always land on the specified Strapped VRX channel first even when more than one channel is on its allowed channels list.

In Car Monitor (ICM)

The ICM feature allows the MSU to monitor PSU Voice traffic and is configurable in the MSU codeplug as follows:

- ICM is enabled / disabled globally in the MSU via the 'ICM Allowed' Field
- If 'ICM Allowed' is programmed in the MSU then ICM operation is further configured on a per MSU channel basis via the 'ICM Allowed' codeplug field.
- ICM functionality is further configured to be triggered by either Hang Up Box (HUB) on / off transitions OR via menu item / button on the MSU control head or keypad microphone.

When ICM functionality is configured to be triggered via HUB on/off then 'ICM Selected' operation takes place when the MSU microphone is placed on HUB, 'ICM All' operation will take place when the MSU microphone is taken off HUB.

For details on how to program the ICM functionality and options in the MSU, please refer to the corresponding Motorola Solutions Documentation.

When the MSU is operating on a Trunking FNE with ICM enabled the following configurations are available:

- 'ICM Selected' – the MSU speaker unmutes to PSU audio matching its selected TG ID (digital VRX channel) or all qualified analog PSU audio (analog VRX channel).
- 'ICM All' – the MSU speaker unmutes to all PSU audio regardless of the TG ID (digital VRX channel) or all analog PSU audio (analog VRX channel).

When the MSU is operating on a Conventional FNE with ICM enabled the following configurations are available:

- 'ICM Selected' and MSU configured for Selective Squelch – the MSU speaker will unmute only to PSU audio matching its selected TG (digital VRX channels) or qualified analog audio (analog VRX channels)
- 'ICM Selected' and MSU configured for Normal Squelch – the MSU speaker will unmute to any PSU TG audio (digital VRX channels) or qualified analog PSU audio (analog VRX channels).
- 'ICM All' – the MSU speaker unmutes to all PSU audio

Primary / Secondary Operation Basics

The VRX1000 has a built-in simulcast prevention mechanism, which prevents more than one VRX1000 to transmit on the same frequency, at the same time, in the same location.

NOTE:

The algorithm is intended to operate in stationary, same scene scenarios only. It cannot be applied to moving vehicles. **Moving vehicles must either have the VRX1000 switched OFF or 'VR Disabled' MSU mode selected.**

The VRX1000 units are capable of communicating with each other and negotiating which VRX1000 is a Primary, i.e. elected to transmit, and which VRX1000s are Secondary for as long as there is a Primary.

The simulcast prevention algorithm has two phases:

- Primary / Secondary Phase
- Busy Lockout Phase

During the 'Primary / Secondary' phase, the VRX1000 units exchange P25 messages. When a VRX1000 is activated (switched to System or Local mode), it sends a query – "Is there a Primary?" If it receives a Primary (or Permanent Primary) 'Heart Beat', then the VRX1000 assumes Secondary state. If no Primary Heart Beat is received, the VRX1000 becomes the Primary and starts sending 'Primary Heart Beats' notifying other VRX1000s of its status.

The 'Secondary' VRX1000s monitor any VRX1000-related activity while in a Standby mode and execute Primary/Secondary checks periodically.

The 'Primary' VRX1000 facilitates any communication requests in the area and periodically communicates its status to the other VRX1000s.

The Busy Lockout phase serves as an added protection by forcing the Primary VRX1000 to check for any activity on its Tx frequency prior to transmitting.

The Primary / Secondary Status of a VRX1000 is re-evaluated every time one of the following takes place:

- Change of VRX1000 channel frequency
- Change of VRX1000 mode
- Remote activation of another VRX1000
- Selecting a VRX1000 Disabled TG / Channel on the MSU
- Powering down a VRX1000
- Detected presence or absence of another Primary
- User enforced Permanent Primary status



| | PRIMARY | STANDBY | PERMANENT PRIMARY |
|-------------------|--|--|--|
| DEFINITION | An active VRX1000 which has won the voting selection and has been selected to repeat Local PSU or System communications. | An active VRX1000 which was voted off and forced to stay on stand-by, without repeating for as long as the elected Primary VRX1000 is servicing the communication needs in the area. | An active VRX1000, which is forced by the user or programmed to act as a Primary. The Permanent Primary forces all other VRX1000s in the area to assume Secondary status. If more than one Permanent Primary is available in the same area, it will go through higher level voting to elect one winning Permanent Primary. |
| SELECTION | Transparent to the user selection via VRX1000 voting algorithm. | Transparent to the user selection via VRX1000 voting algorithm. | Press the DVRS button on the MSU CH to enter the 'DVR/VRX Control Menu', then press the PM button to toggle Permanent Primary Status ON and OFF if such selection is enabled in the VRX1000 personality. |
| DISPLAY | Steady  | Flashing  | Steady  |

Table 9 Primary VRX1000 Definitions

NOTE:

As an option, an external light may be placed on the top of the vehicle, which can be used to indicate which VRX1000 is the currently selected Primary.

Permanent Primary Activation

If programmed, a VRX1000 can be forced to be a Permanent Primary from the MSU CH.

NOTE:

If another Permanent Primary is already present, the newly activated Permanent Primary VRX1000 will force the “old” Permanent Primary to assume Permanent Primary ‘On Standby’ Status. If the Permanent Primary leaves the scene, the Permanent Primary ‘On Standby’ takes over. If several users try to simultaneously activate several VRX1000 units as Permanent Primaries, the VRX1000s will go through voting to ensure only one Permanent Primary is selected and all other VRX1000s are forced to become Permanent Primary ‘On Standby’.

Permanent Primary Deactivation

The Permanent Primary status of a VRX1000 can be switched off from the MSU CH.

Legacy Mobexcom II Voting Compatibility Mode

The voting compatibility mode is applicable to analog VRX1000 mode only. If Legacy Mobexcom II Voting Compatibility mode is enabled in the VRX1000, its voting algorithm is compatible with older style analog only Mobexcom II VRs. Enabling this feature allows seamless replacement of old style VRs with the new VRX1000 by supporting the deployment of both types of units in the same fleet during the transition period.

VRX1000 Voting Compatibility Modes

| Voting Compatibility | VRX1000 | | DVRS | AVE (Analog Interface to APX MSU) | |
|--------------------------------|-------------|-----------------------|--------------|-----------------------------------|--------------|
| | Non VRS-750 | VRS-750 Mode (future) | Simplex Mode | Non VRS-750 | VRS-750 Mode |
| VRX1000 Non VRS-750 | YES | NO | YES | YES | NO |
| VRX1000 VRS-750 Mode | NO | YES | NO | NO | YES |
| DVRS Simplex Mode | YES | NO | YES | YES | NO |
| AVE Non VRS-750 | YES | NO | YES | YES | NO |
| AVE VRS-750 Mode | NO | YES | NO | NO | YES |

Table 10 VRX1000 Voting Compatibility

MSU Scan

Supported MSU Scan Types

The MSU Scan feature is allowed while the VRX1000 is active (System or Local Mode) if the MSU Scan type is configured as one of the following:

- Conventional
- Multi-System Talkgroup
- Priority Monitor
- Voting

VRX1000 Enabled / Disabled Rules while MSU Scan is enabled

The Selected VRX1000 channel settings are used across all MSU scan channels except when the VRX1000 operation is Disabled for the given MSU channel.

If the VRX1000 selected channel is Digital and the MSU scans to an analog channel, the VRX1000 will become temporarily disabled.

If the Selected MSU channel is programmed as VRX1000 Disabled, the VRX1000 operation will remain disabled even if the MSU scans to a channel which is VRX1000 Enabled.

The VRX1000 will become temporarily disabled if the MSU lands on a channel that is programmed as VRX1000 Disabled. In this scenario the VRX1000 will not handle Outbound calls received by the MSU but will still repeat Inbound PSU calls by reverting the MSU to its selected channel.

Outbound Calls (received by MSU from the FNE) with MSU Scan Enabled

If the MSU is configured to only unmute to a specific TG ID or NAC, only the audio containing the specified TG ID or NAC will be proxied by the VRX1000 to the PSU.

Individual call signaling (Page, Call Alert, Message, Radio inhibit etc) originating from a secondary (not the MSU selected) channel is not proxied by the VRX1000 to the PSU.

Emergency Alarm / Call originating from a secondary channel are supported through the VRX1000.

Inbound Calls (received by VRX1000 from PSU) with MSU Scan Enabled

MSU Talkback and Designated TX are not supported when a PSU makes a call through the VRX1000 while the MSU has SCAN enabled. The MSU always moves back from the landed to the selected channel when the PSU initiates a call through the VRX1000.

Talkback and Designated TX are supported only for MSU initiated calls.

MSU ISSI Roaming

The NGI (New Generation Interoperability) feature and VRX1000 feature will be allowed such that a VRX1000 MSU enabled subscriber may also be enabled for InterWACN-Roaming in the subscriber codeplug. When the MSU roams to a foreign System the VRX1000 will display “VR Limited” to indicate to the user the limited functionality available. When the MSU has roamed to the foreign system, the following features are not supported for the local PSU.

- Private Call
- Telephone Interconnect
- Call Alert
- Dynamic Regrouping
- Radio Check
- Multisystem Scan
- Selector Lock
- Status
- Message
- Remote Monitor
- Reprogram Request
- Radio Inhibit

Unsupported Features

The following PSU features are not presently supported by the VRX1000 and ‘VRX/DVRS Enabled’ PSUs:

- Evac Tone
 - Hearclear
 - DTMF Hot Keypad
 - Securenet
 - Soft ID
 - QCII
 - Singletone
 - Conventional OTAR
 - Authentication Demand packets
 - Over-the-Air-Channel Reassignment (OTACR)
 - Over-the-Air Channel Steering (OTACS)
 - Over-the-Air-Programming (OTAP)
 - PSU Scan
 - Priority Channel PTT
 - PSU Reprogram request / Selector Lock
 - PSU Smart PTT
 - PSU Announcement Group operation
-

-
- PSU Phase II P25 conventional operation

NOTE:

The unsupported PSU features list provided above may NOT include ALL unsupported features. Please contact Motorola Solutions for specific feature support information.

NOTE:

Due to FCC Exposure licensing limitations, when the User PTTs the MSU Microphone, only one of the transmitters is allowed to be keyed up (VRX or MSU) as described in **Table 7** and **Table 8**.

P25 Digital Mode Operation

This chapter provides details on the VRX1000 Digital P25 mode of operation.

The P25 Digital mode assumes the following:

- APX MSU Programmed for VRX1000 Operation
- P25 FDMA only mode is selected on the MSU.
- P25 PSU programmed for VRX1000 operation (Local PSU).
- VRX1000 Enabled mode selected on the Local PSU.
- VRX1000 channel programmed as Digital or Mixed or Forced Analog Mode of Operation.

NOTE:

The **Local PSU** notation throughout this chapter refers to a P25 PSU which is used to communicate with / through the VRX1000.

'**VRX/DVRS Enabled**' type **Local PSU** refers to the models described in **Table 4** when programmed for VRX1000 operation.

Some of the Digital mode features described are only available in P25 'VRX/DVRS Enabled' type PSUs and not available in Generic P25 PSUs (refer to **Table 4**). The use of 'VRX/DVRS Enabled' PSUs and associated features through the VRX1000 require that the VRX has Option **TT05953AA**.

A **System PSU** refers to a P25 PSU which has a P25 Mode (Trunking or Conventional) selected and communicates directly with the P25 Trunking or Conventional System, i.e. without a VRX1000.

In cross-band applications, the **Local PSUs** operate in different frequency band from the system infrastructure, i.e. from the **System PSUs**.

The same PSU may be used as System and / or Local PSU depending on its currently selected mode.

PSU Affiliation

When a local PSU user selects a VRX Enabled TG, the Local PSU is affiliated via an active Primary VRX1000 if:

- The selected VRX1000 channel is programmed for Digital or Mixed or Forced Analog mode.
- The same Digital RF channel (with matched NACs) is selected on both the PSU and the VRX1000.
- The PSU Conventional Astro ID and TG ID are valid on the FNE.
- The MSU is on a P25 Mode (VRX Enabled) thus allowing P25 VRX1000 operation.

Generic P25 PSU is registered during the first Group Call made after switching to the VRX enabled mode. 'VRX/DVRS Enabled' P25 PSU starts automatic affiliation process upon selection of VRX Enabled Mode (no PTT required to start affiliation process). The maximum number of PSUs that can get affiliated with one VRX1000 is 256.

Group Calls

Inbound and Outbound Group Calls are supported by the VRX1000.

MSU Priorities

| MSU Priority Level | Activity |
|--------------------|---|
| LOW | Idle (incl. in Emergency Call, not receiving audio) Group Voice Receive (all group call types, including hangtime while on trunked voice channel) Packet Data |
| MEDIUM | Transmitting Signaling features (call alert, status etc.) Individual Calls (unit to unit and Phone) |
| HIGH | Emergency Alarm Emergency Call Transmit Emergency Call Receive MSU Mode Change, Power Down |

Table 11 MSU Priorities

PSU Proxy Request Priorities

| PSU Proxy Request Priority Level | Proxy Request |
|----------------------------------|-----------------------------------|
| HIGH | Emergency Alarm Emergency Call |
| LOW | All other Proxy Requests |

Table 12 PSU Proxy Request Priorities

MSU Voice and Signaling Proxy Interactions

The MSU handles interactions with a PSU voice or signaling proxy request from the VRX1000 based on the following general priority rules:

- MSU Emergency overrides all proxies including PSU emergency alarm / emergency call.
- PSU Emergency overrides all MSU non-emergency proxies
- MSU PTT and signaling features (call alert, status etc) override all PSU non-emergency proxies
- PSU non-emergency proxies override MSU receive

Talk Group Proxing

The Local PSU User can change the selected 'DVRs/VRX Enabled' TG and seamlessly talk to the corresponding TG users through the VRX1000. The MSU can be on any 'DVRs/VRX Enabled' TG, which may or may not match the TG selected by the Local PSU. For example, if the Local PSU selects TG1 while the MSU is on TG2, the Local PSU can talk to Local TG1 users (in Talk Around) as well as System TG1 users via the VRX1000 i.e. the MSU will be transmitting on TG1. If the MSU microphone is PTT-ed, the MSU will transmit on the TG selected on the MSU i.e. TG2. An outbound call received by the MSU on either TG1 or TG2 will be repeated by the VRX1000 to the Local PSUs.

If Proxing is Disabled then the Local PSU and the MSU must have the same TG selected in order to enable Local PSU affiliation and communications.

Talk Group Translation

When TG translation is enabled in the VRX1000 for a specific PSU TG ID, then any call that is received by the VRX1000 from the Local PSU with this TG ID will be translated to the ID of the TG currently selected on the MSU's control head. The Local PSU could be programmed with just one TG ID and if this ID is programmed in the VRX1000 TG Translation list, the PSU call will always be translated by the VRX1000 to the TG ID currently selected on the MSU control head. For instance, if the Local PSU is on TG A, which is programmed in the VRX1000 TG Translation list and the MSU is on TG B then all inbound Local PSU calls will be repeated by the VRX1000 to the FNE on TG B. If the MSU mode is then switched to TG C then the Local PSU calls will be repeated on TG C to the FNE.

Generic (non-DVRs/VRX Enabled) Conventional P25 PSUs that are not enabled for talkgroup operation will, by default, use TG ID 1 when transmitting. If TG ID 1 is added to the VRX1000 Translation table then PSUs transmitting TG ID 1 will be translated to the TG selected on the MSU.

IMPORTANT!

TG Translation requires that TG Proxing is enabled.

When TG proxing is enabled and the TG selected on the Local PSU is programmed in the VRX1000 Translation Table, the VRX1000 will affiliate the Local PSU on the TG that is selected on the MSU. If TG Proxing is enabled but the Local PSU is on a TG that is not in the VRX1000 TG Translation list then the VRX1000 will proxy any inbound / outbound calls on the PSU TG ID. Outbound call (system originated call) received on the currently

selected MSU TG is repeated 'as is' i.e. without any translation. Therefore the Local PSUs need to be programmed with Normal Squelch (or NID = F7E) in order to hear those calls.

IMPORTANT!

Encryption Key Translation is not supported by the VRX1000.

Private Calls

Private Calls (Local to System PSU; System to Local PSU) are supported on 'DVRs/VRX Enabled' PSUs only.

NOTE:

Inbound and Outbound Private Calls are not supported on 'Generic P25' PSUs or if the VRX1000 does not have Option **TT05953AA** Installed.

PSU Talk Permit Tones

'Go Ahead' tones are generated in the 'DVRs/VRX Enabled' PSUs. Different tones are generated to indicate if the VRX1000 is in Local or System Mode or the call is P25 Encrypted. As a programming option Local Mode tones can be generated when the System is busy and only Local mode is available. Alternatively, the PSU user can get 'System Busy' tones and be forced to wait for system grant (see '**Digital System Setup Menu**' in the **DVRs Programming** section). Talk Permit Tones are NOT supported when using Generic P25 PSU mode.

NOTE:

PSU Talk Permit Tones are not supported on 'Generic P25' PSUs or if the VRX1000 does not have Option **TT05953AA** Installed.

Status Broadcast

If enabled in the VRX1000 (“**Network Status Reporting Interval**”, Digital System setup screen), the VRX1000 transmits status broadcasts that can be received only by P25 “DVRs/VRX Enabled” PSUs:

- FNE Out of Range
- VRX1000 Local only status
- Site Trunking
- IV&D Data Enabled / Disabled status

NOTE:

Only a **Primary** VRX1000 can transmit Status Broadcasts.

The above status indication is not available to Generic P25 PSUs or if the VRX1000 does NOT have Option TT05953AA installed. The status indication is passed to the Local PSU every time the status changes. If there is no change to the status, the VRX1000 sends status indication to the Local PSUs at a preprogrammed time interval. The VRX1000 also sends a network status notification every time a Local PSU is affiliated with the FNE via VRX1000. If the FNE enters Failsoft mode, the MSU proxies the Failsoft message (if Failsoft is enabled in the MSU), the VRX1000 stops sending Status Broadcast to the Local “DVRs/VRX Enabled” PSUs and periodically transmits Failsoft message instead.

NOTE:

Status Broadcast is not supported on ‘Generic P25’ PSUs or if the VRX1000 does not have Option **TT05953AA** Installed.

Local Mode Indication

When the VRX1000 is operating in the LOCAL mode, the “DVRs/VRX Enabled” PSU User can see “**LOCAL ONLY**” message displayed on the PSU screen. The above indication is only available on ‘DVRs/VRX Enabled’ P25 PSUs.

NOTE:

Local Mode Indication is not supported on ‘Generic P25’ PSUs or if the VRX1000 does not have Option **TT05953AA** Installed.

Radio Check / Inhibit

Radio Check and Radio Inhibit functions are passed through the VRX1000 to the Local PSU when the VRX1000 is in the SYSTEM or LOCAL mode. Those functions are available to both ‘DVRs/VRX Enabled’ and Generic P25 PSUs when the MSU is operating on a P25 Trunked or P25 Conventional Mode. If the MSU gets radio inhibited, the VRX1000 switches to ‘VR Disabled’ mode of operation.

P25 Trunking OTAR

P25 over the Air Rekeying (OTAR) is supported through the VRX1000 when the Local PSUs are of the ‘DVRs/VRX Enabled’ type, the VRX1000 is in the SYSTEM mode and the MSU is on a P25 Trunking mode. OTAR is not supported on a P25 conventional MSU channels.

NOTE:

P25 Trunked OTAR is not supported on 'Generic P25' PSUs or if the VRX1000 does not have Options **TT05952AA** and **TT05953AA** Installed.

Patch

When several TGs are patched on the system side (using the trunking group-regrouping function), the VRX1000 ensures the patching is matched on the local PSU side when 'DVRs/VRX1000 Enabled' PSUs are used, the VRX1000 is in the SYSTEM or LOCAL mode and the MSU is on a P25 Trunking TG.

IMPORTANT!

System design must ensure that PSU TGs that are programmed for TG Translation are outside of the range of talkgroups used on the trunking system.

MSU Patch is supported as follows:

- Inbound call from PSU on TG Translation enabled TG will be translated to the patch supergroup and repeated locally and to the system.
- Outbound call will be repeated as is (with the supergroup TG ID).

NOTE:

Patch is not supported on 'Generic P25' PSUs or if the VRX1000 does not have Option **TT05953AA** Installed.

Dynamic Regrouping

The Dynamic Regrouping feature allows a dispatcher to remotely redirect subscribers to operate on a designated TG without any intervention from the subscriber unit operator. This is done by remotely assigning a new TG for the subscriber to operate on. When the subscriber receives the request, it automatically switches to the assigned zone / channel. The VRX1000 extends this functionality to the 'DVRs/VRX Enabled' Local PSUs when the VRX1000 is in the SYSTEM or LOCAL mode and the MSU is operating on a P25 trunked channel. PSU Reprogram request (PSU requesting to be dynamically regrouped or ungrouped) and Selector Lock / Unlock (disabling / enabling the zone/channel selection functionality while a PSU is dynamically regrouped) are not presently supported via the VRX1000.

NOTE:

Dynamic Regrouping is not supported on 'Generic P25' PSUs or if the VRX1000 does not have Option **TT05953AA** Installed.

Phone Interconnect

Phone Interconnect is NOT supported on the VRX1000.

Adaptive Power Control

The VRX1000 can be programmed to send P25 messages to the Local PSUs to adjust their transmit power depending on the received signal strength from the VRX1000 and thereby to conserve the PSU battery. Enabling this feature is NOT recommended in applications where more than one PSU are typically used with a single VRX since it will affect the PSU-to-PSU communications.

NOTE:

Adaptive Power Control is supported on both 'Generic P25' XTS/APX PSUs as well as on "DVRs/VRX Enabled" PSUs.

Digital Audio Buffering

Audio buffering is supported by the VRX1000 in order to eliminate loss of messages / parts of messages due to the inherent delays associated with acquiring system access. The Digital Audio Buffer in the VRX1000 is programmable up to 1800ms.

P25 Encryption

The VRX1000 transparently passes the P25 encryption algorithms used by the subscriber and fixed network equipment. Even though the VRX1000 can be programmed to support TG translation, it cannot support encryption key translation. When the VRX1000 is on a P25 Digital channel, inbound digital audio from a Local PSU is handled according to the following table:

| Local PSU Call | MSU Secure Strapping | Receiving Local PSUs | Receiving FNE |
|----------------|----------------------|----------------------|---------------|
| P25 Clear | Clear or Secure | P25 Clear | P25 Clear |
| P25 Encrypted | Clear or Secure | P25 Encrypted | P25 Encrypted |

Table 13 Inbound P25 Encryption Rules

While the VRX1000 is on a Digital channel, outbound digital audio originating from the FNE is handled according to the following table:

| Call from FNE | MSU Secure Strapping | Receiving Local PSUs |
|---------------|----------------------|----------------------|
| P25 Clear | Clear or Secure | P25 Clear |
| P25 Encrypted | Clear or Secure | P25 Encrypted |

Table 14 Outbound P25 Encryption Rules

While the VRX1000 is on a Digital channel, outbound digital audio originating from the MSU is handled according to the following table:

| MSU Mode | MSU Secure Strapping | Receiving Local PSUs |
|-------------|----------------------|----------------------|
| Digital P25 | Clear | P25 Clear |
| Digital P25 | Secure | P25 Encrypted |

Table 15 MSU MIC PTT P25 Encryption Rules

The MSU interfaced to the VRX1000 will unmute to Inbound or Outbound Encrypted P25 calls ONLY if the MSU contains the key used for encryption in its Encryption Key List.

NOTE:

P25 Encryption support requires Option **TT05952AA** to be installed in the VRX1000.

Remote VRX1000 Activation and Steering by PSU Call Alert (Page)

A P25 PSU may be programmed to send a Call Alert (Page) and preprogrammed Network ID (NID) to a specific VRX1000 and thereby remotely change:

- VRX1000 Mode (from OFF or Local to System)
- VRX1000 Status (Secondary / Primary)
- Selected TG / Channel on MSU

NOTE:

Remote change of MSU Mode has no effect on the operation of the rest of the PSUs in the area since the TG Proxing feature allows multiple TG operation. This applies to Mode change within the same system, and when TG Translation is not enabled

The VRX1000 is addressed by sending a call alert (page) with the specific programmed VRX1000 ID.

NOTE:

All VRX1000 should have unique IDs programmed in the digital mode settings menu if the remote control feature is to be used. If no VRX1000 ID is programmed, the VRX1000 will assume the ID of the MSU currently interfaced to it. Remote activation and steering are supported when the MSU ID = VRX1000 ID.

The remote VRX1000 status change will not be successful if there is another Permanent Primary already present in the area (see [Table 16](#)).

The following table illustrates some typical remote steering scenarios:

| Local PSU | VRX1000 A Steering | | VRX1000 B Steering | |
|--|---|--|---|---|
| | BEFORE | AFTER | BEFORE | AFTER |
| Call Alert (Page) to: VRX1000 A PSU on TG 1 | OFF OR LOCAL SECONDARY VR CH 1 MSU TG 1 | SYSTEM PRIMARY VR CH 1 MSU TG 1 | LOCAL OR SYSTEM PRIMARY VR CH 1 MSU TG 1 | LOCAL OR SYSTEM SECONDARY VR CH 1 MSU TG 1 |
| Call Alert (Page) to: VRX1000 A PSU on TG 1 | OFF OR LOCAL SECONDARY VR CH 1 MSU TG 1 | SYSTEM SECONDARY VR CH 1 MSU TG 1 | LOCAL OR SYSTEM PERM. PRIMARY VR CH 1 MSU TG 1 | LOCAL OR SYSTEM PERM. PRIMARY VR CH 1 MSU TG 1 |
| Call Alert (Page) to: VRX1000 A PSU on TG 2 | OFF OR LOCAL SECONDARY VR CH 1 MSU TG 1 | SYSTEM PRIMARY VR CH 1 MSU TG 2 | LOCAL OR SYSTEM PRIMARY VR CH 1 MSU TG 1 | LOCAL OR SYSTEM SECONDARY VR CH 1 MSU TG 1 |
| Call Alert (Page) to: VRX1000 A PSU on TG 2 | OFF OR LOCAL SECONDARY VR CH 1 MSU TG 1 | SYSTEM SECONDARY VR CH 1 MSU TG 2 | LOCAL OR SYSTEM PERM. PRIMARY VR CH 1 MSU TG 1 | LOCAL OR SYSTEM PERM. PRIMARY VR CH 1 MSU TG 1 |
| Call Alert (Page) to: VRX1000 A PSU on CONV1 | OFF OR LOCAL SECONDARY VR CH 1 MSU TG 1 | SYSTEM PRIMARY VR CH 1 MSU CONV1 | LOCAL OR SYSTEM PRIMARY VR CH 1 MSU TG 1 | LOCAL OR SYSTEM SECONDARY VR CH 1 MSU TG 1 |
| Call Alert (Page) to: VRX1000 A PSU on TG1 | OFF OR LOCAL SECONDARY VR CH 1 MSU CONV1 | SYSTEM PRIMARY VR CH 1 MSU TG 1 | LOCAL OR SYSTEM PRIMARY VR CH 1 MSU TG 1 | LOCAL OR SYSTEM SECONDARY VR CH 1 MSU TG 1 |

Table 16 Typical Remote Steering Scenarios

Emergency in Digital Mode

The 'DVRs/VRX Enabled' P25 PSU can be programmed to block the launch of the Emergency feature if the P25 Trunking system is in failsoft mode (when 'Emergency Blocked in Failsoft' is enabled). The 'DVRs/VRX Enabled' P25 PSU can be programmed to use the programmed 'Revert Talkgroup' while in Emergency and when on the Dynamic Talkgroup channel without an assigned dynamic working group.

Emergency Alarm

When an affiliated Local PSU issues an Emergency Alarm, the active Primary VRX1000 will process the Emergency to the system as follows:

- If the '**Portable ID Display**' box (in the VRX1000 **Emergency Mode Setup**) is checked, the local PSU unit ID will be displayed on the MSU control head of the current Primary VRX1000.
- The PSU unit ID will also appear on the display of the other local PSUs if they are programmed accordingly.
- During Emergency Call, the unit ID of the local PSU, which has initiated the Emergency Call, may be displayed on the system PSUs / MSUs if those are programmed accordingly.
- The local PSU ID during Emergency may also be displayed on the dispatcher console.

- The VRX1000 sends back an Emergency ACK to prevent the PSU from re-sending the Emergency either right after the VRX1000 decodes the Emergency request (if the '**System Acknowledge Type**' on the **Mobile Radio Channel Settings** menu is set to "**VR Ack**") or after FNE ACK has been received (if the '**System Acknowledge Type**' on the **Mobile Radio Channel Settings** menu is set to '**Site Ack**' or '**Console Ack**').
- All Secondary VRX1000 in the area are monitoring the number of emergencies issued by local PSUs according to the '**Attempts Timeout**' and '**Attempts Counter**' settings programmed in the VRX1000s **Emergency Mode Setup**. If the number of detected but not serviced Emergency Attempts exceeds the counter, the Secondary VRX1000s will go through Primary / Secondary voting to select a new Primary to pass the emergency to the System.
- If a VRX1000 is in the OFF Mode when it receives an Emergency from a local PSU, the VRX1000 will switch to System mode after the '**Attempts Counter**' is exceeded, affiliate the PSU and pass the Emergency to the System.
- If a VRX1000 is on a 'VR Disabled' Mode and it receives an Emergency from a local PSU with a valid steering NAC then after the '**Attempts Counter**' is exceeded, the VRX1000 will steer to the corresponding 'VR Enabled' MSU mode, switch to SYSTEM mode, affiliate the PSU and pass the Emergency to the System.

The PSU Emergency attempts counter must be programmed to be equal to the VRX1000 '**Attempts Counter**' plus 3.

Emergency Call

Emergency Call operation provides the user with access to a voice resource on a priority basis. The user's Emergency Call has priority over all other types of call traffic.

Upon receipt of an Emergency Call from a local PSU, the VRX1000 will proxy the call to the FNE. The VRX1000 also updates its display to indicate the PSUs Emergency Call condition. Upon PSU Cancellation of the Emergency Call, the VRX1000 will clear its emergency display. The VRX1000 will also proxy the PSU emergency cancellation to the P25 FNE. Emergency Hot MIC enables automatic emergency voice transmission without having to press the PSU PTT. PSU Emergency Hot Mic is supported only on 'DVRs/VRX Enabled' PSUs. Only the 'DVRs/VRX Enabled' PSU waits for Emergency Alarm ACK before requesting a voice channel. If Emergency Hot MIC is enabled in Generic P25 PSUs (or 'DVRs/VRX Enabled' XTS PSUs with firmware older than R12.00.13), the PSU will send emergency alarm and immediately enter the call phase, which prevents consistent emergency processing.

Emergency Revert through VRX1000

When the VRX1000 is programmed for emergency revert and the MSU is not already in Emergency, the VRX1000 steers the MSU to the preprogrammed zone/channel upon receiving and Emergency Alarm / Call from the PSU. When the VRX1000 receives emergency cancellation from the PSU, it steers the MSU back to the original zone / channel, provided the MSU is not in emergency and the user has not manually changed the MSU channel.

Emergency Revert through PSU

The PSU can be configured to revert to a preprogrammed talkgroup or zone / channel when it enters Emergency. With the Talkgroup revert option, the PSU does not change its mode but rather stays on the currently selected channel and performs all emergency related voice and signaling by using the Revert Talkgroup ID. Talkgroup revert is only supported on the APX 'DVRs/VRX Enabled' PSUs.

Emergency operation during TG Translation

Emergency operation is affected by TG Translation as follows:

- **Inbound Emergency Alarm** received by the VRX1000 on TG X will be translated to the ID of the TG selected on the MSU and forwarded to the FNE.
- **Outbound Emergency Alarm** received by the MSU on the MSU selected TG (TG Y) will be translated and repeated to the local PSUs on all translated TG IDs that are selected on all Local PSUs, currently affiliated with the VRX1000.
- **Inbound Emergency Call** on TG X will be translated by the VRX1000 to the ID of the TG selected on the MSU and will be repeated on the translated TG to the FNE.
- **Outbound Emergency call** received on TG Y selected on the MSU will be repeated by the VRX1000 to the Local PSUs on TG Y.
- If Emergency Revert is programmed in the local PSU then:
- If the revert TG is on the VRX1000 TG Translation list, then the Emergency will be translated to the ID of the TG that is selected on the MSU.
- If the revert TG is not in the VRX1000 TG Translation list then the emergency will be proxied and the inbound and outbound repeat will be on the new emergency revert TG.

- If the MSU (interfaced to the Primary DVR) is placed in Emergency and programmed to revert in Emergency then a subsequent local PSU emergency will also be translated and declared on the MSU's emergency revert TG.

Fireground (FG) Signaling

The VRX1000 supports FG Emergency signaling transmission from the Local PSU to the FNE (if programmed in the VRX1000). Other types of FG signaling are discarded and only the Local PSU user's voice is transmitted from the Local PSU to the FNE in FG applications.

PSU IV&D

The VRX1000 supports IV&D for only one PSU at any time. The use of PSU IV&D requires P25 'DVRs/VRX Enabled' PSUs, a VRX1000 in LOCAL or SYSTEM mode operating on a P25 digital or Forced Analog channel, and MSU operating on a P25 Trunked mode. Voice operation and signaling (such as call alert etc.) initiated from the MSU or PSU take priority over data operation.

NOTE:

PSU IV&D is not supported on 'Generic P25' PSUs or if the VRX1000 does not have Option **TT05953AA** Installed.

PSU Location Reporting

PSU location reporting is supported on 'DVRs/VRX Enabled' PSUs when the MSU is operating on a P25 Trunked mode. This feature relies on PSU IV&D functionality described above.

NOTE:

PSU Location is not supported on 'Generic P25' PSUs or if the VRX1000 does not have Option **TT05953AA** Installed.

PSU Call Alert

PSU Call Alert is supported via the VRX1000 when the MSU is operating on a P25 Trunked or P25 Conventional mode and when the PSU is either P25 '*DVRs/VRX Enabled*' or *P25 Generic*.

PSU Message

The Message feature is supported on all types of P25 PSUs when the MSU is operating on a P25 Conventional mode only.

PSU Status Update and Status Request

The PSU Status Update & Status Request features are supported on all types of P25 PSUs when the MSU is operating on a P25 Conventional or P25 trunked mode.

Automatic PSU Revert to Talk Around (TA)

The 'DVRs/VRX Enabled' PSU can be programmed to automatically revert to TA and continue to operate when it goes outside of the VRX1000 radio coverage range. This way,

simplex PSU-to-PSU calls ('DVRs/VRX Enabled' PSUs) will be allowed regardless of the presence or absence of the VRX1000.

NOTE:

Adaptive Power Control is supported on both 'Generic P25' XTS/APX PSUs as well as on "DVRs/VRX Enabled" PSUs.

PSU Group Services

Pre-requisites for PSU Group Services support via VRX1000:

- APX series 'VRX1000/DVRs Enabled' PSUs with Firmware R14.50.00 or later
- P25 Trunked FNE with firmware 7.16 or later
- VRX1000 with firmware R1.22 / MSU R14.50.00 or later
- VRX1000 in SYSTEM or LOCAL Mode, Digital Channel Selected
- MSU that VRX1000 is interfaced to receiving Group Services while on P25 Trunked **FDMA** Mode

The following Group Services can be supported by the VRX1000:

Group Text

Group text is an unconfirmed message that is sent to all members of a talkgroup. The VRX1000 passes the Group Text messages to the local PSUs. If the Local 'VRX1000/DVRs Enabled' PSU users want to receive only Group Text Messages sent to the PSU selected Talkgroup, then the PSU must be programmed for 'Selective Squelch' instead of the default 'Normal Squelch'. If programmed for 'Normal Squelch', the Local PSU will receive all Group Text Messages proxied by the VRX1000 regardless of the Talkgroup currently selected on the PSU.

NOTE:

The above also applies to voice calls in general – if the Local PSU users want their PSUs to only unmute to the PSU selected Talkgroup, then they need to program 'Selective Squelch' in the PSU. If they are using the default 'Normal Squelch' setting, the PSUs will unmute to all calls proxied by the VRX1000 regardless of the incoming call Talkgroup.

Group Alias Update

Group Alias update is a message sent to a given Talkgroup while on a voice channel to alert the receiving radio of the transmitting radio's alias/ID configured in the Provisioning Manager on the console. The updated Group Alias data is received by the members of the Talkgroup and their Unified Call List (UCL) is updated. The VRX1000 passes the Group Alias Update to the local 'VRX1000/DVRS Enabled' PSUs so that their UCLs can get the update even while they are not directly connected to the trunked system but are proxied via the VRX1000.

NOTE:

The updated Alias will be displayed on the receiving PSU only when the PSU is directly affiliated on the trunking system. When affiliated through the VRX1000, the PSU will still display the Unit ID of the transmitting PSU but it will not display the programmed or the updated Alias for that transmitting Unit ID.

NOTE:

When the MSU is operating on TDMA mode, the MSU may receive group services but will not proxy those to the VRX1000 / Local PSUs.

Digital Mode – P25 Conventional Support

When only **TT05951AA** (P25 Phase 1 Operation) option is enabled, in addition to all Analog mode features, the VRX1000 also supports basic P25 functionality with P25 Generic PSUs. “DVRs/VRX Enabled” PSUs are NOT supported. “DVRs/VRX Enabled” PSUs and the associated Enhanced Trunking like features require **TT05953AA** (P25 Enhanced Trunking Features) option to be enabled.

P25 Digital VRX1000 Mode with P25 Conventional Mode Selected on MSU

| FEATURE | VRX1000 OFF Mode | VRX1000 SYSTEM Mode | VRX1000 LOCAL Mode |
|---|------------------------|---------------------|--------------------|
| Status Display on MSU CH | VR OFF <VRX CH> | VR SYS <VRX CH> | VR LOC <VRX CH> |
| PSU Affiliation | No | Yes | Yes |
| Talk Group Proxing / Translation | No | Yes | Yes |
| Outbound Group Call | No | Yes | Programmable |
| Outbound Private Call | No | No | No |
| MSU Microphone PTT | Keys up MSU only | Keys up MSU only | As programmed* |
| Inbound Group Call | No | Yes | Yes |
| PSU PTT ID Pass Through | No | Yes | Yes |
| Inbound Private Call | No | No | No |
| Inbound Call Alert | No | Yes | Yes |
| PSU Talk Permit Tones | No | Yes | Yes |
| PSU Emergency Alarm | Yes (after activation) | Yes | Yes |
| PSU Emergency Revert | No | Yes | Yes |
| PSU Emerg. ID Pass Through | Yes (after activation) | Yes | Yes |
| PSU Remote VRX1000 Activation & Steering | Yes – Call Alert | Yes – Call Alert | Yes – Call Alert |
| Failsoft / Out of Range / Site Trunking Indication on PSU | NA | NA | NA |
| PSU Local Mode Indication | No | No | Yes |
| Primary / Secondary Voting | No | Yes | Yes |
| VRX1000 Tones – MSU Speaker | No | Yes | Yes |
| PSU Radio Check / Inhibit | No | Yes | Yes |
| PSU GPS | No | No | No |
| PSU P25 Trunking OTAR | NA | NA | NA |
| PSU Patch | NA | NA | NA |
| PSU Dynamic Regrouping | NA | NA | NA |
| PSU Selector Lock /Unlock | NA | NA | NA |
| PSU Phone Interconnect | NA | NA | NA |
| PSU Adaptive Power Control | No | Yes | Yes |
| Audio Buffering | No | Yes | NA |
| PSU Scan | No | No | No |
| PSU Announcement Group | No | No | No |
| PSU P25 Encryption | No | Yes | Yes |
| PSU Status / Message | No | Yes | Yes |

**The APX MSU can be programmed so that MSU MIC PTT keys up either VRX1000 OR MSU side but not both.*

P25 Digital VRX1000 Mode (Generic P25 PSUs) with P25 Trunked (FDMA) Mode Selected on MSU

“DVRs/VRX Enabled” PSUs are blocked as indicated below and require **TT05953AA** (P25 Enhanced Trunking Features) option in order to be enabled through the VRX1000.

| FEATURE | VRX1000 OFF Mode | VRX1000 SYSTEM Mode | VRX1000 LOCAL Mode |
|---|------------------------|---------------------|--------------------|
| Status Display on MSU CH | VR OFF <VRX CH> | VR SYS <VRX CH> | VR LOC <VRX CH> |
| PSU Affiliation | No | No | No |
| Talk Group Proxing / Translation | No | Yes | Yes |
| Outbound Group Call | No | Yes | Programmable |
| Outbound Private Call | No | No | No |
| MSU Microphone PTT | Keys up MSU only | Keys up MSU only | As programmed* |
| Inbound Group Call | No | Yes | No |
| PSU PTT ID Pass Through | No | Yes | Yes |
| Inbound Private Call | No | No | No |
| Inbound Call Alert | No | Yes | Yes |
| PSU Talk Permit Tones | No | No | No |
| PSU Emergency Alarm | Yes (after activation) | Yes | Yes |
| PSU Emergency Revert | No | Yes | Yes |
| PSU Emerg. ID Pass Through | Yes (after activation) | Yes | Yes |
| PSU Remote VRX1000 Activation & Steering | Yes – Call Alert | Yes – Call Alert | Yes – Call Alert |
| Failsoft / Out of Range / Site Trunking Indication on PSU | No | No | No |
| PSU Local Mode Indication | No | No | No |
| Primary / Secondary Voting | No | Yes | Yes |
| VRX1000 Tones – MSU Speaker | No | Yes | Yes |
| PSU Radio Check / Inhibit | No | Yes | Yes |
| PSU GPS | No | No | No |
| PSU P25 Trunking OTAR | No | No | No |
| PSU Patch | No | No | No |
| PSU Dynamic Regrouping | No | No | No |
| PSU Selector Lock /Unlock | No | No | No |
| PSU Phone Interconnect | No | No | No |
| PSU Adaptive Power Control | No | No | No |
| Audio Buffering | No | Yes | NA |
| PSU P25 Encryption | No | Yes | Yes |
| PSU Scan | No | No | No |
| PSU Announcement Group | No | No | No |
| PSU Status / Message | No | Status only | Status only |

**The APX MSU can be programmed so that MSU MIC PTT keys up either VRX1000 OR MSU side but not both.*

Digital Mode – P25 Enhanced Trunking Features Support

When the VRX1000 has options **TT05951AA** (P25 Phase I Operation) , **TT05952AA** (P25 Encryption) and **TT05953AA** (P25 Enhanced Trunking Features), it can be used with “DVRs/VRX Enabled” PSUs and provides support for various Enhanced P25 Trunking system features as well as Forced Analog Mode as described in the Tables below and in the **Forced Analog Mode** section of this document.

P25 Digital VRX1000 Mode with P25 Conventional Mode Selected on MSU

| FEATURE | VRX1000 OFF Mode | VRX1000 SYSTEM Mode | VRX1000 LOCAL Mode |
|---|------------------------|---------------------|--------------------|
| Status Display on MSU CH | VR OFF <VRX CH> | VR SYS <VRX CH> | VR LOC <VRX CH> |
| PSU Affiliation | No | Yes | Yes |
| Talk Group Proxing / Translation | No | Yes | Yes |
| Outbound Group Call | No | Yes | Programmable |
| Outbound Private Call | No | No | No |
| MSU Microphone PTT | Keys up MSU only | Keys up MSU only | As programmed* |
| Inbound Group Call | No | Yes | Yes |
| PSU PTT ID Pass Through | No | Yes | Yes |
| Inbound Private Call | No | No | No |
| Inbound Call Alert | No | Yes | Yes |
| PSU Talk Permit Tones | No | Yes | Yes |
| PSU Emergency Alarm | Yes (after activation) | Yes | Yes |
| PSU Emergency Revert | No | Yes | Yes |
| PSU Emerg. ID Pass Through | Yes (after activation) | Yes | Yes |
| PSU Remote VRX1000 Activation & Steering | Yes – Call Alert | Yes – Call Alert | Yes – Call Alert |
| Failsoft / Out of Range / Site Trunking Indication on PSU | NA | NA | NA |
| PSU Local Mode Indication | No | No | Yes |
| Primary / Secondary Voting | No | Yes | Yes |
| VRX1000 Tones – MSU Speaker | No | Yes | Yes |
| PSU Radio Check / Inhibit | No | Yes | Yes |
| PSU GPS | No | No | No |
| PSU P25 Trunking OTAR | NA | NA | NA |
| PSU Patch | NA | NA | NA |
| PSU Dynamic Regrouping | NA | NA | NA |
| PSU Selector Lock /Unlock | NA | NA | NA |
| PSU Phone Interconnect | NA | NA | NA |
| PSU Adaptive Power Control | No | Yes | Yes |
| Audio Buffering | No | Yes | NA |
| PSU Scan | No | No | No |
| PSU Announcement Group | No | No | No |
| PSU P25 Encryption | No | Yes | Yes |
| PSU Status / Message | No | Yes | Yes |

**The APX MSU can be programmed so that MSU MIC PTT keys up either VRX1000 OR MSU side but not both.*

P25 Digital VRX1000 Mode with P25 Trunked (FDMA) Mode Selected on MSU

| FEATURE | VRX1000 OFF Mode | VRX1000 SYSTEM Mode | VRX1000 LOCAL Mode |
|---|------------------------|---------------------|--------------------|
| Status Display on MSU CH | VR OFF <VRX CH> | VR SYS <VRX CH> | VR LOC <VRX CH> |
| PSU Affiliation | No | Yes | Yes |
| Talk Group Proxing / Translation | No | Yes | Yes |
| Outbound Group Call | No | Yes | Programmable |
| Outbound Private Call | No | Yes | Yes |
| MSU Microphone PTT | Keys up MSU only | Keys up MSU only | As programmed* |
| Inbound Group Call | No | Yes | No |
| PSU PTT ID Pass Through | No | Yes | Yes |
| Inbound Private Call | No | Yes | Yes |
| Inbound Call Alert | No | Yes | Yes |
| PSU Talk Permit Tones | No | Yes | Yes |
| PSU Emergency Alarm | Yes (after activation) | Yes | Yes |
| PSU Emergency Revert | No | Yes | Yes |
| PSU Emerg. ID Pass Through | Yes (after activation) | Yes | Yes |
| PSU Remote VRX1000 Activation & Steering | Yes – Call Alert | Yes – Call Alert | Yes – Call Alert |
| Failsoft / Out of Range / Site Trunking Indication on PSU | No | Yes | No |
| PSU Local Mode Indication | No | No | Yes |
| Primary / Secondary Voting | No | Yes | Yes |
| VRX1000 Tones – MSU Speaker | No | Yes | Yes |
| PSU Radio Check / Inhibit | No | Yes | Yes |
| PSU GPS | No | Yes | Yes |
| PSU P25 Trunking OTAR | No | Yes | Yes |
| PSU Patch | No | Yes | Yes |
| PSU Dynamic Regrouping | No | Yes | Yes |
| PSU Selector Lock /Unlock | No | No | No |
| PSU Phone Interconnect | No | No | No |
| PSU Adaptive Power Control | No | Yes | Yes |
| Audio Buffering | No | Yes | NA |
| PSU P25 Encryption | No | Yes | Yes |
| PSU Scan | No | No | No |
| PSU Group Services | No | Yes | Yes |
| PSU Announcement Group | No | No | No |
| PSU Status / Message | No | Status only | Status only |

**The APX MSU can be programmed so that MSU MIC PTT keys up either VRX1000 OR MSU side but not both.*

Forced Analog Mode

Forced Analog Mode is a hybrid mode in which the communications between the 'DVRs/VRX Enabled' PSU and the 'DVRs/VRX Enabled' P25 PSU are P25 digital, while the voice communications are 'forced' to be analog when the MSU is on a non-P25 channel / Talkgroup. Forced analog mode is used only when the Local PSUs are 'DVRs/VRX Enabled'. When the MSU is on analog conventional or 3600 Baud trunking (analog or digital) or P25 TDMA channel, the DVRs/VRX1000 'forces' the 'DVRs/VRX Enabled' PSU to transmit analog voice. When the MSU is on a P25 channel / talkgroup, the 'DVRs/VRX Enabled' PSU and the VRX1000 operate in P25 digital mode. At all times the signaling between the 'DVRs/VRX Enabled' PSUs and the VRX1000 is digital P25. The VRX1000 must be on a VRX1000 channel programmed for 'F.Analog' mode.

IMPORTANT!

Forced Analog Mode requires Option TT05953AA to be loaded in the VRX1000. 'Generic P25' PSUs can't operate with a VRX1000 in Forced Analog Mode.

Forced Analog All DVR Mode- Operation and Programming Overview

Forced Analog All Mode is a hybrid mode in which the communications between the DVRs and the 'DVRs Enabled' P25 PSU are P25 digital, while the voice communications are 'forced' to be analog for all MSU channels. At all times the signaling between the DVRs Enabled PSUs and the DVRs is digital P25. The DVRs must be on a DVR channel programmed for 'F.Analog All' mode as described in the **'Repeater Channel Setup Menu'** section.

IMPORTANT!

Generic P25 PSUs cannot operate with a DVRs in Forced Analog All Mode.

IMPORTANT!

The PSU and DVR PL/DPLs must be programmed to be properly matched. The DVRs Enabled PSU must be programmed for mixed receive in order to be able to program PL on a 'DVRs Enabled' channel.

Forced Analog Mode – Summary of Features

When the VRX1000 has options **TT05951AA** (P25 Phase I Operation) , **TT05952AA** (P25 Encryption) and **TT05953AA** (P25 Enhanced Trunking Features), it can be used with “DVRs/VRX Enabled” PSUs and provides support for various Enhanced P25 Trunking system features as well as Forced Analog Mode as described in the Tables below.

Forced Analog VRX1000 Mode with P25 Trunking TDMA Mode Selected on MSU

This mode is supported on ‘DVRs/VRX Enabled’ PSUs only.

| FEATURE | VRX1000 OFF Mode | VRX1000 SYSTEM Mode | VRX1000 LOCAL Mode |
|---|------------------------|---------------------|--------------------|
| Status Display on MSU CH | VR OFF <VRX CH> | VR SYS <VRX CH> | VR LOC <VRX CH> |
| PSU Affiliation | No | Yes | Yes |
| Talk Group Proxing | No | No | No |
| Outbound Group Call | No | Yes | Programmable |
| Outbound Private Call | No | No | No |
| MSU Microphone PTT | Keys up MSU only | Keys up MSU only | As programmed* |
| Inbound Group Call | No | Yes | Yes |
| PSU PTT ID | No | Yes | Yes |
| Inbound Private Call | No | No | No |
| Inbound Call Alert | No | Yes | Yes |
| PSU Talk Permit Tones | No | Yes | Yes |
| PSU Emergency Alarm | Yes (after activation) | Yes | Yes |
| PSU Emergency Call | No | Yes (group call) | Yes (group call) |
| PSU Emergency Revert via VRX1000 | No | Yes | Yes |
| PSU Emergency ID Pass Through | Yes (after activation) | Yes | Yes |
| PSU Remote VRX1000 Activation & Steering | Yes (Call Alert) | Yes | Yes (Call Alert) |
| MSU Mode Steering | No | Yes (Call Alert) | Yes (Call Alert) |
| Failsoft / Out of Range / Site Trunking Indication on PSU | No | Yes | No |
| PSU Local Mode Indication | No | No | Yes |
| Primary / Secondary Voting | No | Yes | Yes |
| VRX1000 Tones – MSU Speaker | No | Yes | Yes |
| PSU Radio Check / Inhibit | No | Yes | Yes |
| PSU GPS | No | No | No |
| PSU P25 Trunking OTAR | NA | NA | NA |
| PSU Patch | No | No | No |
| PSU Dynamic Regrouping | No | No | No |
| PSU Selector Lock /Unlock | No | No | No |
| PSU Phone Interconnect | No | No | No |
| PSU Adaptive Power Control | No | Yes | Yes |
| Audio Buffering | No | Yes | NA |
| PSU Scan | No | No | No |
| PSU Announcement Group | No | No | No |
| PSU P25 Encryption | No | No | Yes ** |
| PSU Status / Message | No | Status only | Status only |

*The APX MSU can be programmed so that MSU MIC PTT keys up either VRX1000 OR MSU side but not both. ** P25 Encryption supported in direct mode i.e. local PSU to local PSU; no ICM support

Forced Analog VRX1000 Mode with 3600 Trunking Mode Selected on MSU

This mode is supported on 'DVRs/VRX Enabled' PSUs only.

| FEATURE | VRX1000 OFF Mode | VRX1000 SYSTEM Mode | VRX1000 LOCAL Mode |
|---|------------------------------|------------------------------|------------------------------|
| Status Display on the MSU CH | VR OFF <VRX CH> | VR SYS <VRX CH> | VR LOC <VRX CH> |
| PSU Affiliation | No | No | No |
| Talk Group Proxing | No | No | No |
| Outbound Group Call | No | Yes | Programmable |
| Outbound Private Call | No | No | No |
| MSU Microphone PTT | Keys up MSU only | Keys up MSU only | As programmed* |
| Inbound Group Call | No | Yes | Yes |
| PSU PTT ID | No | No | No |
| Inbound Private Call | No | No | No |
| Inbound Call Alert | No | No | No |
| PSU Talk Permit Tones | No | Yes | Yes |
| PSU Emergency Alarm | Yes (after activation) | Yes | Yes |
| PSU Emergency Call | No | Yes (group call) | Yes (group call) |
| PSU Emergency Revert via VRX1000 | No | Yes | Yes |
| PSU Emerg. ID Pass Through | Yes (after activation) | Yes (with Emergency Alarm) | Yes (with Emergency Alarm) |
| PSU Remote VRX1000 Activation & Steering | Yes – Call Alert | Yes – Call Alert | Yes – Call Alert |
| Failsoft / Out of Range / Site Trunking Indication on PSU | No | Yes | No |
| PSU Local Mode Indication | No | No | Yes |
| Primary / Secondary Voting | No | Yes | Yes |
| VRX1000 Tones – MSU Speaker | No | Yes | Yes |
| PSU Radio Check /Inhibit | No | No | No |
| PSU GPS | No | No | No |
| PSU P25 Trunking OTAR | NA | NA | NA |
| PSU Patch | No | No | No |
| PSU Dynamic Regrouping | No | No | No |
| PSU Selector Lock / Unlock | No | No | No |
| PSU Phone Interconnect | No | No | No |
| PSU Adaptive Power Control | No | No | No |
| Audio Buffering | No | Yes | NA |
| PSU Scan | No | No | No |
| PSU Announcement Group | No | No | No |
| P25 Encryption | No | No | Yes ** |
| PSU Status / Message | No | No | No |

**The APX MSU can be programmed so that MSU MIC PTT keys up either VRX1000 OR MSU side but not both.*

*** P25 Encryption supported in direct mode i.e. local PSU to local PSU; no ICM support*

Forced Analog VRX1000 Mode with Conventional Analog Mode Selected on MSU

This mode is supported on 'DVRs/VRX Enabled' PSUs ONLY.

| FEATURE | VRX1000 OFF Mode | VRX1000 SYSTEM Mode | VRX1000 LOCAL Mode |
|---|------------------------------|------------------------------|------------------------------|
| Status Display on the MSU CH | VR OFF <VRX CH> | VR SYS <VRX CH> | VR LOC <VRX CH> |
| PSU Affiliation | No | No | No |
| Talk Group Proxing | No | No | No |
| Outbound Group Call | No | Yes | Programmable |
| Outbound Private Call | No | No | No |
| MSU Microphone PTT | Keys up MSU only | Keys up MSU only | As programmed* |
| Inbound Group Call | No | Yes | Yes |
| PSU PTT ID | No | No | No |
| Inbound Private Call | No | No | No |
| Inbound Call Alert | No | No | No |
| PSU Talk Permit Tones | No | Yes | Yes |
| PSU Emergency Alarm | Yes (after activation) | Yes | Yes |
| PSU Emergency Revert via VRX1000 | No | Yes | Yes |
| PSU Emerg. ID Pass Through | No | Yes | Yes |
| PSU Remote VRX1000 Activation & Steering | Yes – Call Alert | Yes – Call Alert | Yes – Call Alert |
| Failsoft / Out of Range / Site Trunking Indication on PSU | NA | NA | NA |
| PSU Local Mode Indication | No | No | Yes |
| Primary / Secondary Voting | No | Yes | Yes |
| VRX1000 Tones – MSU Speaker | No | Yes | Yes |
| PSU Radio Check / Inhibit | No | No | No |
| PSU GPS | No | No | No |
| PSU P25 Trunking OTAR | NA | NA | NA |
| PSU Patch | NA | NA | NA |
| PSU Dynamic Regrouping | NA | NA | NA |
| PSU Selector Lock / Unlock | NA | NA | NA |
| PSU Phone Interconnect | NA | NA | NA |
| PSU Adaptive Power Control | No | No | No |
| Audio Buffering | No | Yes | NA |
| PSU Scan | No | No | No |
| PSU Announcement Group | No | No | No |
| PSU P25 Encryption | No | Programmable | Programmable |
| PSU Status / Message | No | Yes | Yes |

**The APX MSU can be programmed so that MSU MIC PTT keys up either VRX1000 OR MSU side but not both.*

Analog Mode Operation

This Chapter provides details on the VRX1000 Analog Mode of operation.

The Analog Mode assumes the following:

- APX4500 or APX6500 or APX7500 MSU Programmed for DVRS/VRX Operation.
- PSU programmed for DVRS/VRX operation using a Conventional, Analog, non-ASTRO Personality.
- VRX1000 Channel used is programmed for Analog (or Mixed) Mode of Operation.

VRX1000 Channel Setup for Analog Mode

To enable Analog VRX1000 operation on a specific VRX1000 channel the Channel Type (in the Repeater Channel Setup Menu) must be set to **Analog**. The VRX1000 Tx = Rx Frequency / Frequencies as well as the Tx / Rx PL or DPL must be programmed to match the corresponding PSU settings.

NOTE:

Mixed VRX1000 mode allows Analog VRX1000 operation by switching between digital and analog modes as described in the Mixed VRX1000 Mode section. The use of mixed mode for analog VRX1000 communications is not recommended since it requires special user training in order to handle the switching between default digital and temporary analog mode. Mixed VRX1000 mode should only be used when both analog and digital PSUs are required to operate on the same VRX1000 channel.

Group Calls

An analog local PSU in VRX1000 mode can communicate with other analog local PSUs in Talk Around mode. Inbound Local PSU calls will be repeated on the MSU side over the currently selected MSU TG / Channel. Outbound calls received by the MSU are repeated to the Local Analog PSUs.

Emergency in Analog Mode

The Emergency operation in analog mode is based on the type of signaling as selected in the Emergency Mode Setup Menu. The recommended analog mode signaling type is MDC1200. MDC1200 signaling must be enabled in the local PSU personality. If MDC1200 signaling is used, the Local PSU Emergency Alarm MDC ID will be passed through to the system provided the MDC ID is enabled (valid) on the system side.

NOTE:

PSU PTT ID (MDC1200) pass-through is not supported by VRX1000 on Type 2 trunking MSU modes.

Only Emergency ID (with Emergency Alarm) pass-through is supported by the VRX1000 on Type 2 trunking MSU modes.

Emergency Alarm

When an affiliated local PSU issues an Emergency Alarm, the active Primary VRX1000 will process the emergency to the system as follows:

- If the **'Portable ID Display'** box (in the VRX1000 **Emergency Mode Setup**) is checked, the Local PSU Unit ID will be displayed on the MSU control head of the current Primary VRX1000.
- The PSU Unit ID will also appear on the display of the other local PSUs if they are programmed accordingly.
- The local PSU ID during Emergency may also be displayed on the dispatcher console.
- The VRX1000 sends back an Emergency ACK to prevent the PSU from re-sending the Emergency either right after the VRX1000 decodes the Emergency request (if the **'System Acknowledge Type'** on the **Mobile Radio Channel Settings** menu is set to **"VR Ack"**) or after FNE ACK has been received (if the **'System Acknowledge Type'** on the **Mobile Radio Channel Settings** menu is set to **'Site Ack'** or **'Console Ack'**).
- All Secondary VRX1000 in the area are monitoring the number of emergencies issued by local PSUs according to the **'Attempts Timeout'** and **'Attempts Counter'** settings programmed in the VRX1000s **Emergency Mode Setup**. If the number of detected not serviced Emergency Attempts exceeds the counter, the Secondary VRX1000s will go through Primary / Secondary voting to select a new Primary to pass the emergency to the system.
- If a VRX1000 is in the OFF mode when it receives an Emergency from a local PSU, the VRX1000 will switch to SYSTEM mode after the **'Attempts Counter'** is exceeded, affiliate the PSU and pass the Emergency to the system.

The PSU Emergency attempts counter must be programmed to be equal to the VRX1000 **'Attempts Counter'** plus 3.

Emergency Call

Emergency Call operation provides the user with access to a voice resource on a priority basis. The user's Emergency Call has priority over all other types of call traffic. Upon receipt of an Emergency Call from a local PSU, the VRX1000 will process the call locally

as well as proxy the call to the FNE. On Type II trunking systems, the PSU Emergency Call will be proxied with the **MSU Emergency ID**, NOT the PSU MDC ID. The VRX1000 also updates its display to indicate the PSUs Emergency Call condition.

Emergency Revert

When the VRX1000 is programmed for emergency revert and the MSU is not already in Emergency, the VRX1000 steers the MSU to the preprogrammed zone/channel upon receiving and Emergency Alarm / Call from the PSU. The emergency revert condition can be configured as permanent or timed. If configured as timed then the VRX1000 will revert the MSU back to the original channel after the emergency inactivity timer expires without inbound or outbound activity.

Analog Audio Buffering

Audio buffering is supported by the VRX1000 in order to eliminate loss of messages / parts of messages due to the inherent delays associated with acquiring system access. The analog buffer is programmable in the VRX1000 (up to 1300ms).

Tactical Public Safety (TPS)

The TPS feature allows analog subscribers to send digital PTT ID information on an analog channel with analog voice. TPS is only supported when the VRX1000 is on an analog channel in the SYSTEM mode and the MSU is configured for analog transmit (without any signaling) and with Mixed receive.

Fireground (FG) Signaling

The VRX1000 supports FG Emergency signaling transmission from the Local PSU to the FNE (if programmed in the VRX1000). Other types of FG signaling are discarded and only the Local PSU user's voice is transmitted from the Local PSU to the FNE in FG applications.

Remote VRX1000 Activation via DTMF

The local PSU may be programmed to remotely activate the VRX1000 by switching it from OFF or LOCAL to SYSTEM mode by sending a pre-programmed DTMF sequence. The remote activation only works if the Local PSU and the VRX1000 are set to operate on the same radio channel.

IMPORTANT!

The VRX1000 cannot be switched OFF remotely via DTMF.

P25 Encryption in Analog Mode

If the MSU is receiving a P25 Encrypted call while the VRX1000 is operating on analog channel, the VRX1000 can be programmed to do one of the following:

- Forward encrypted audio to the local PSUs
- Forward clear audio to the local PSUs
- Send warning tones to the local PSUs and no audio

P25 Encrypted audio received by the MSU is processed by the VRX1000 as described below:

| Call from FNE received by MSU | VRX1000 Programming for Outbound Encrypted Calls | VRX1000 Transmits to receiving Local PSUs |
|-------------------------------|--|---|
| P25 Encrypted | Transmit Encrypted | P25 Encrypted* |
| P25 Encrypted | Transmit Clear | Clear Analog |
| P25 Encrypted | Send Warning Tones | Warning Tones |

*Local PSUs must be configured for Mixed receive.

Leading & Trailing Tones

The VRX1000 can be programmed to send over-the-air Leading or Trailing tones to the LPSUs to indicate successful MSU key up / system access.

If Leading Tones are enabled, the local PSU operation involves the following:

- User does a quick PTT of LPSU so that MSU can request channel grant
- User releases the PTT for a moment and waits to hear the Leading tones.
- If the Leading tones indicate successful system access (channel grant), the LPSU user PTTs again and talks.
- If the Leading tones indicate lack of channel grant, the LPSU user can try the call again.

Trailing tones are sent at the end of LPSU transmission and therefore do not require double PTT.

Both Leading and Trailing Tones are sent over-the-air (i.e. not generated in the PSU that initiates the call) therefore all LPSUs that are within the VRX1000 range and switch to the VRX1000 channel will hear the tones.

Mobile Mode Steering via PL/DPL

This feature allows a PSU User to remotely change the currently selected MSU mode by transmitting with a pre-programmed PL/DPL. When the VRX1000 decodes the PL/DPL it finds the corresponding MSU mode in its look-up table and steers the MSU to the new mode. Depending on the programming, the MSU may either stay on the new mode or it may revert after a preprogrammed timer expires to the originally selected MSU mode. The preprogrammed timer (**'MSU Mode Steering Hang Time'**, **Analog Setup**) starts after the local PSU (causing the steering) keys off.

Steering and Emergency

- If steering is disabled on the current VRX1000 channel, local PSU emergency is declared on the currently selected MSU channel (no steering).
- If steering is enabled on the current VRX1000 channel, the local PSU emergency is declared on the new (steered) MSU mode.
- When MSU is in emergency call state (**'Put DVR in Emergency Call State'** is enabled), the local PSU calls handling is defined by the **'Steering in Emergency'** programming for the specific VRX1000 channel. If **'Steering in Emergency'** is Disabled, the VRX1000 repeats any local PSU calls on the emergency channel (no steering occurs).
- If **'Steering in Emergency'** is enabled, the VRX1000 will steer and then key up the MSU. In this case the MSU will re-declare Emergency call on the new (steered to) channel.
- If **'Put DVR in Emergency Call State'** is Disabled (local PSU and MSU programmed for Emergency Alarm only), an inbound local PSU call initiated while the MSU is waiting for emergency ACK, should terminate MSU emergency and steer the MSU to the corresponding MSU mode/channel without re-declaring the emergency alarm on the new MSU channel.

MSU Operating on TDMA (P25, Phase 2)

When the MSU is switched to a TDMA capable mode, the VRX1000 can operate in either Analog, Forced Analog, Forced Analog All or Digital mode.

For Forced Analog & Forced Analog All mode operation, please refer to the **Forced Analog & Forced Analog All Mode** section of this document.

When operating on TDMA system, any TDMA specific feature that can cause the MSU to interrupt an ongoing transmission will also affect the proxying of Local PSU transmissions to the system. The Local PSU will not receive an indication that its proxy transmission from the MSU to the system may have gotten interrupted.

Analog Mode – Summary of Features

Analog VRX1000 Mode with P25 Trunking Mode (FDMA) Selected on MSU

| FEATURE | VRX1000 OFF Mode | VRX1000 SYSTEM Mode | VRX1000 LOCAL Mode |
|---|--------------------------------|---------------------------------|---------------------------------|
| Status Display on MSU CH | VR OFF <VRX CH> | VR SYS <VRX CH> | VR LOC <VRX CH> |
| PSU Affiliation | No | Yes | Yes |
| Talk Group Proxing | No | No | No |
| Outbound Group Call | No | Yes | Programmable |
| Outbound Private Call | No | No | No |
| MSU Microphone PTT | Keys up MSU only | Keys up MSU only | As programmed* |
| Inbound Group Call | No | Yes | Yes |
| PSU PTT ID Pass Through | No | Yes | Yes |
| Inbound Private Call | No | No | No |
| Inbound Call Alert | No | No | No |
| PSU Leading/Trailing Tones | No | As Programmed | As Programmed |
| PSU Emergency Alarm | Yes (after activation) | Yes | Yes |
| PSU Emergency Call | No | Yes (group call) | Yes (group call) |
| PSU Emergency Revert via VRX1000 | No | Yes | Yes |
| PSU Emerg. ID Pass Through | Yes (after MDC1200 activation) | Yes – MDC1200 with Emerg. Alarm | Yes – MDC1200 with Emerg. Alarm |
| PSU Remote VRX1000 Activation | Yes – DTMF | NA | Yes – DTMF |
| MSU Mode Steering | No | Yes (PL/DPL) | Yes (PL/DPL) |
| Failsoft / Out of Range / Site Trunking Indication on PSU | No | No | No |
| PSU Local Mode Indication | No | No | No |
| Primary / Secondary Voting | No | Yes | Yes |
| VRX1000 Tones – MSU Speaker | No | Yes | Yes |
| PSU Radio Check / Inhibit | No | No | No |
| PSU GPS | No | No | No |
| PSU P25 Trunking OTAR | No | No | No |
| PSU Patch | No | No | No |
| PSU Dynamic Regrouping | No | No | No |
| PSU Selector Lock /Unlock | No | No | No |
| PSU Phone Interconnect | No | No | No |
| PSU Adaptive Power Control | No | No | No |
| Audio Buffering | No | Yes | NA |
| PSU Scan | No | No | No |
| PSU Announcement Group | No | No | No |
| PSU P25 Encryption | No | Yes (except Tier 1) | Yes (except Tier 1) |
| PSU Status / Message | No | Yes Status only | Yes Status only |

**The APX MSU can be programmed so that MSU MIC PTT keys up either VRX1000 OR MSU side but not both.*

Analog VRX1000 Mode with P25 Conventional Mode Selected on MSU

| FEATURE | VRX1000 OFF Mode | VRX1000 SYSTEM Mode | VRX1000 LOCAL Mode |
|---|--------------------------------|---------------------------------|---------------------------------|
| Status Display on MSU CH | VR OFF <VRX CH> | VR SYS <VRX CH> | VR LOC <VRX CH> |
| PSU Affiliation | No | No | No |
| Talk Group Proxing | No | No | No |
| Outbound Group Call | No | Yes | Programmable |
| Outbound Private Call | No | No | No |
| MSU Microphone PTT | Keys up MSU only | Keys up MSU only | As programmed* |
| Inbound Group Call | No | Yes | Yes |
| PSU PTT ID Pass Through | No | Yes | Yes |
| Inbound Private Call | No | No | No |
| Inbound Call Alert | No | No | No |
| PSU Leading / Trailing Tones | No | Yes | Yes |
| PSU Emergency Alarm | Yes (after activation) | Yes | Yes |
| PSU Emergency Revert | No | Yes | Yes |
| PSU Emerg. ID Pass Through | Yes (after MDC1200 activation) | Yes – MDC1200 with Emerg. Alarm | Yes – MDC1200 with Emerg. Alarm |
| PSU Remote VRX1000 Activation | Yes – DTMF | NA | Yes – DTMF |
| MSU Mode Steering | No | Yes (PL/DPL) | Yes (PL/DPL) |
| Failsoft / Out of Range / Site Trunking Indication on PSU | NA | NA | NA |
| PSU Local Mode Indication | No | No | No |
| Primary / Secondary Voting | No | Yes | Yes |
| VRX1000 Tones – MSU Speaker | No | Yes | Yes |
| PSU Radio Check / Inhibit | No | No | No |
| PSU GPS | No | No | No |
| PSU P25 Trunking OTAR | NA | NA | NA |
| PSU Patch | NA | NA | NA |
| PSU Dynamic Regrouping | NA | NA | NA |
| PSU Selector Lock /Unlock | NA | NA | NA |
| PSU Phone Interconnect | No | No | No |
| PSU Adaptive Power Control | No | No | No |
| Audio Buffering | No | Yes | NA |
| PSU Scan | No | No | No |
| PSU Announcement Group | No | No | No |
| PSU P25 Encryption | No | Yes (except Tier 1) | Yes (except Tier 1) |
| PSU Status / Message | No | Yes | Yes |

**The APX MSU can be programmed so that MSU MIC PTT keys up either VRX1000 OR MSU side but not both.*

Analog VRX1000 Mode with Conventional Analog Mode Selected on MSU

| FEATURE | VRX1000 OFF Mode | VRX1000 SYSTEM Mode | VRX1000 LOCAL Mode |
|---|--------------------------------|---------------------------------|---------------------------------|
| Status Display on MSU CH | VR OFF <VRX CH> | VR SYS <VRX CH> | VR LOC <VRX CH> |
| PSU Affiliation | No | No | No |
| Talk Group Proxing | No | No | No |
| Outbound Group Call | No | Yes | Programmable |
| Outbound Private Call | No | No | No |
| MSU Microphone PTT | Keys up MSU only | Keys up MSU only | As programmed* |
| Inbound Group Call | No | Yes | Yes |
| PSU PTT ID Pass Through | No | Yes | Yes |
| Inbound Private Call | NA | NA | NA |
| Inbound Call Alert | No | No | No |
| PSU Leading / Trailing Tones | No | Yes | Yes |
| PSU Emergency Alarm | Yes (after activation) | Yes | Yes |
| PSU Emergency Revert via VRX1000 | No | Yes | Yes |
| PSU Emerg. ID Pass Through | Yes (after MDC1200 activation) | Yes – MDC1200 with Emerg. Alarm | Yes – MDC1200 with Emerg. Alarm |
| PSU Remote VRX1000 Activation | Yes – DTMF | NA | Yes – DTMF |
| MSU Mode Steering | No | Yes (PL/DPL) | Yes (PL/DPL) |
| Failsoft / Out of Range / Site Trunking Indication on PSU | NA | NA | NA |
| Local Mode Indication on PSU | No | No | No |
| Primary / Secondary Voting | No | Yes | Yes |
| VRX1000 Tones – MSU Speaker | No | Yes | Yes |
| PSU Radio Check / Inhibit | No | No | No |
| PSU GPS | No | No | No |
| P25 Trunking OTAR | NA | NA | NA |
| PSU Patch | NA | NA | NA |
| PSU Dynamic Regrouping | NA | NA | NA |
| PSU Selector Lock / Unlock | NA | NA | NA |
| PSU Phone Interconnect | NA | NA | NA |
| PSU Adaptive Power Control | NA | NA | NA |
| Audio Buffering | No | Yes | NA |
| PSU Scan | No | No | No |
| PSU Announcement Group | No | No | No |
| PSU P25 Encryption | No | Yes (except Tier 1) | Yes (except Tier 1) |
| PSU Status / Message | No | Yes | Yes |

**The APX MSU can be programmed so that MSU MIC PTT keys up either VRX1000 OR MSU side but not both.*

Analog VRX1000 Mode with 3600 Baud Analog or Digital Trunking Mode Selected on MSU

| FEATURE | VRX1000 OFF Mode | VRX1000 SYSTEM Mode | VRX1000 LOCAL Mode |
|---|--------------------------------|--|--|
| Status Display on MSU CH | VR OFF <VRX CH> | VR SYS <VRX CH> | VR LOC <VRX CH> |
| PSU Affiliation | No | No | No |
| Talk Group Proxing | No | No | No |
| Outbound Group Call | No | Yes | Programmable |
| Outbound Private Call | No | No | No |
| MSU Microphone PTT | Keys up MSU only | Keys up MSU only | As programmed* |
| Inbound Group Call | No | Yes | Yes |
| PSU PTT ID Pass Through | No | No | No |
| Inbound Private Call | No | No | No |
| Inbound Call Alert | No | No | No |
| PSU Leading / Trailing Tones | No | Yes | Yes |
| PSU Emergency Alarm | Yes (after activation) | Yes | Yes |
| PSU Emergency Call | No | Yes (group call, using MSU unit ID and TG) | Yes (group call, using MSU unit ID and TG) |
| PSU Emergency Revert via VRX1000 | No | Yes | Yes |
| PSU Emerg. ID Pass Through | Yes (after MDC1200 activation) | Yes – MDC1200 with Emerg. Alarm | Yes – MDC1200 with Emerg. Alarm |
| PSU Remote VRX1000 Activation | Yes – DTMF | NA | Yes – DTMF |
| MSU Mode Steering | No | Yes (PL/DPL) | Yes (PL/DPL) |
| Failsoft / Out of Range / Site Trunking Indication on PSU | No | No | No |
| PSU Local Mode Indication | No | No | No |
| Primary / Secondary Voting | No | Yes | Yes |
| VRX1000 Tones – MSU Speaker | No | Yes | Yes |
| PSU Radio Check / Inhibit | No | No | No |
| PSU GPS | No | No | No |
| PSU P25 Trunking OTAR | NA | NA | NA |
| PSU Patch | No | No | No |
| PSU Dynamic Regrouping | No | No | No |
| PSU Selector Lock /Unlock | No | No | No |
| PSU Phone Interconnect | No | No | No |
| PSU Adaptive Power Control | No | No | No |
| Audio Buffering | No | Yes | NA |
| PSU Scan | No | No | No |
| PSU Announcement Group | No | No | No |
| PSU P25 Encryption | No | No | No |
| PSU Status / Message | No | No | No |

**The APX MSU can be programmed so that MSU MIC PTT keys up either VRX1000 OR MSU side but not both.*

Analog VRX1000 Mode with P25 Phase II (TDMA) Trunking Mode Selected on MSU

| FEATURE | VRX1000 OFF Mode | VRX1000 SYSTEM Mode | VRX1000 LOCAL Mode |
|---|--------------------------------|---------------------------------|---------------------------------|
| Status Display on MSU CH | VR OFF <VRX CH> | VR SYS <VRX CH> | VR LOC <VRX CH> |
| PSU Affiliation | No | Yes | Yes |
| Talk Group Proxing | No | No | No |
| Outbound Group Call | No | Yes | Programmable |
| Outbound Private Call | No | No | No |
| MSU Microphone PTT | Keys up MSU only | Keys up MSU only | As programmed* |
| Inbound Group Call | No | Yes | Yes |
| PSU PTT ID | No | Yes (MDC1200) | Yes (MDC1200) |
| Inbound Private Call | No | No | No |
| Inbound Call Alert | No | No | No |
| PSU Leading / Trailing Tones | No | Yes | Yes |
| PSU Emergency Alarm | Yes (after activation) | Yes | Yes |
| PSU Emergency Call | No | Yes (group call) | Yes (group call) |
| PSU Emergency Revert via VRX1000 | No | Yes | Yes |
| PSU Emerg. ID Pass Through | Yes (after MDC1200 activation) | Yes – MDC1200 with Emerg. Alarm | Yes – MDC1200 with Emerg. Alarm |
| PSU Remote VRX1000 Activation | Yes – DTMF | NA | Yes – DTMF |
| MSU Mode Steering | No | Yes (PL/DPL) | Yes (PL/DPL) |
| Failsoft / Out of Range / Site Trunking Indication on PSU | No | No | No |
| PSU Local Mode Indication | No | No | No |
| Primary / Secondary Voting | No | Yes | Yes |
| VRX1000 Tones – MSU Speaker | No | Yes | Yes |
| PSU Radio Check / Inhibit | No | No | No |
| PSU GPS | No | No | No |
| PSU P25 Trunking OTAR | NA | NA | NA |
| PSU Patch | No | No | No |
| PSU Dynamic Regrouping | No | No | No |
| PSU Selector Lock /Unlock | No | No | No |
| PSU Phone Interconnect | No | No | No |
| PSU Adaptive Power Control | No | No | No |
| Audio Buffering | No | Yes | NA |
| PSU Scan | No | No | No |
| PSU Announcement Group | No | No | No |
| PSU P25 Encryption | No | Yes (except Tier 1) | Yes (except Tier 1) |
| PSU Status / Message | No | Status only | Status only |

**The APX MSU can be programmed so that MSU MIC PTT keys up either VRX1000 OR MSU side but not both.*

Mixed VRX1000 Mode

Mixed VRX1000 mode allows analog VRX1000 operation by switching between digital and analog modes as described below. The use of mixed mode for analog VRX1000 communications is not recommended since it requires special user training to be able to handle the switching between default digital and temporary analog mode as described below.

Mixed VRX1000 mode should only be used when both analog and digital PSUs are required to operate on the same VRX1000 channel. Mixed VRX1000 mode requires the MSU to be switched to a P25 Digital channel. When a VRX1000 channel is programmed to operate in mixed mode, the VRX1000 can handle calls from both P25 and analog local PSUs while the same VRX1000 channel is selected.

When mixed mode is selected, the VRX1000 can be toggled between digital and analog mode as follows:

- The default VRX1000 mode is digital i.e. the P25 modem is enabled by default.
- If a call from a local PSU is detected and the VRX1000 does not decode a P25 frame sync within the preprogrammed '**P25 Frame Sync Detection Timer**', the VRX1000 switches to analog mode and starts decoding analog mode signaling (such as DTMF, MDC1200). The VRX1000 repeats analog signals to the system MSUs / PSUs on the selected MSU channel / TG.
- After the local PSU keys off, the VRX1000 stays in the analog mode for the duration of the preprogrammed '**VR Ch Mixed Mode Hold Timer**'. Any outbound calls which are received by the MSU prior to the above timer's expiration will be repeated by the VRX1000 as analog conventional.
- Once the '**VR Ch Mixed Mode Hold Timer**' expires, the VRX1000 returns back to digital mode and any outbound calls are repeated as digital. Inbound analog calls received by the VRX1000 in mixed mode are repeated to the system by the MSU on the selected TG / Channel.
- If TG Proxing is enabled, digital inbound calls received by the VRX1000 are transmitted by the MSU on the TG selected on the local PSU (not on the TG selected on the MSU).

Special Features Support

TPS Signaling

Tactical Public Safety (TPS) Signaling support can be enabled on a VRX1000 channel, operating in conjunction with a Conventional P25, Trunking P25, or Conventional Analog mobile radio channel. This capability enables specially programmed local PSUs to transmit TPS Leading and / or Trailing IDs. TPS Emergency can also be received and processed by the VRX1000 when a TPS Enabled Analog channel is selected.

Contact Information

Technical Support

905-532-1158
support@futurecom.com

Orders

Please contact Motorola Solutions / Drop Ship

Return Authorizations

1-800-701-9180

Head Office and Manufacturing

3277 Langstaff Rd
Concord, Ontario L4K 5P8
Canada
905-660-5548

www.futurecom.com

Appendix 1 – VRX1000 Specifications

| General Specifications | | | |
|---|---|----------------------|--------------------|
| Dimensions: Height / Width / Depth | 45mm x 175mm x 160mm (cross band, no filters) | | |
| Weight | 2kg / 4.4 lbs (cross band, no filters) | | |
| Channel Spacing | 12.5 or 25 kHz programmable | | |
| Number of Channels | 192 | | |
| Number of MSU Modes (VRX Enabled) | 2047 Entries | | |
| CTCSS/DCS | Programmable per Analog Channel | | |
| Power Supply | 13.8V DC +/- 20%, negative ground only | | |
| DC Current Drain (VRX1000 Only): | | | |
| VRX1000 Off | 0.01 A Max | | |
| VRX1000 Standby | 0.8 A | | |
| VRX1000 Receive | 0.8 A | | |
| Transmit | 3.0 A | | |
| Operating Temperature | -30°C to +60°C | | |
| Storage Temperature | -40°C to +85°C | | |
| Protection Against Liquids | IP54 | | |
| Antenna Impedance | 50 Ohms | | |
| Duty Cycle | 50% Receive / 50% Transmit | | |
| External Connectors: | | | |
| Antenna | Mini UHF | | |
| Computer Interface | Mini USB | | |
| Mobile Radio | DB25 | | |
| Auxiliary / Options | DB15 (Y cable) | | |
| DC Power | M12 Circular | | |
| Equipment Type Acceptance | VHF | UHF | 700 / 800 |
| FCC | LO6-VRX1000VHF | LO6-VRX1000UHF | LO6-VRX1000700800 |
| Industry Canada | 2098B-VRX1000VHF | 2098B-VRX1000UHF | 2098B-VRX10007800 |
| Transmitter Specification | VHF | UHF | 700 / 800 |
| Frequency Band FCC [MHz] | 136-174 | 380-406 406.1-512 | 764-775 851-869 |
| Frequency Band IC [MHz] | 138-174 | 406.1-430 450-470 | 768-776 851-869 |
| Power Output @ Antenna Port | Programmable 0.5 – 3 Watts | | |
| TCT Option | 15 sec to 15 min or Disabled | | |
| Max Spurious Output | -20 dBm | | |
| Frequency Stability (-30°C to +60°C; +25°C Ref.) | +/- 0.75ppm | | |
| FM Hum and Noise 12.5 / 25 kHz | 34 dB / 40 dB | | |
| Audio Response | +1, -3 dB of 6 dB / octave pre-emphasis characteristic over 300 Hz – 3 kHz | | |
| Audio Distortion | <2% | | |
| Receiver Specification | VHF | UHF | 700 / 800 |
| Frequency Band FCC [MHz] | 136-174 | 380-406 | 764-775 |

| | | | |
|--|---------|---|-------------------------------|
| Frequency Band IC [MHz] | 138-174 | 406.1-512 406.1-430 450-470 | 851-869 768-776 851-869 |
| Receiver Sensitivity | | | |
| Analog 12 dB SINAD | | -115 dBm | |
| Digital P25 5% BER | | -115 dBm | |
| Frequency Stability (-30°C to +60°C; +25°C Ref.) | | +/- 0.75ppm | |
| Selectivity 12.5 / 25 kHz | | 60 dB / 70 dB | |
| Intermodulation | | 70 dB | |
| Spurious Rejection | | 70 dB | |
| Analog Mode Deviation 12.5 / 25 kHz | | +/-2.5 kHz / +/-5 kHz | |
| Frequency Deviation for C4FM (P25) | | | |
| Low Level | | 841 – 1037 Hz | |
| High Level | | 2543 – 3110 Hz | |
| Analog Mode FM Hum and Noise 12.5 / 25 kHz | | 34 dB / 40 dB | |
| Audio Output (Repeater Detect Audio) | | 600 mV RMS nominal, flat response | |
| Audio Response | | +1, -3 dB of 6 dB / octave de-emphasis characteristic over 300 Hz – 3 kHz | |
| Audio Distortion | | <2% | |
| Military Standards Compliance | | MIL-STD-810G | |
| High Temperature | | 501.6 I – A1 501.6 II (Operational) | |
| Low Temperature | | 502.6 I – C3 502.6 II (Operational) | |
| Temperature Shock | | 503.6 – C Procedure I | |
| Rain | | 506.6 III | |
| Humidity | | 507.6 Procedure II (Aggravated) | |
| Salt Fog | | 509.6 | |
| Vibration | | 514.7 – I category 24 | |
| Mechanical Shock | | 516.7 Procedure I (Function) 516.7 Procedure VI (Bench Handling) | |

Glossary

| Keyword | Description |
|-----------------------------------|---|
| ACK | Acknowledgement of communications. |
| AVRA | Automated DVR/VRX Activation. Permits automated activation of the DVR/VRX1000 by either using a VIP input on the MSU CH / DEK or a pin on the DVR/VRX1000 Auxiliary cable. Requires external logic / switch, not supplied with the DVRS/VRX1000 Hardware. |
| Band Lock | When enabled, causes the MSU to block usage of the same frequency band as the DVR/VRX1000 while the DVR/VRX1000 is active. Enabled when no in-band filter is present. |
| BL | Busy Lockout – dynamic voting phase (follows the static Primary / Secondary phase) of the DVR/VRX1000 simulcast prevention algorithm. |
| Channel | A group of characteristics, such as transmit / receive frequency pairs, radio parameters, encryption encoding etc. |
| Coded Squelch | Tone Private-Line (PL) or Digital Private-Line (DPL). Used on conventional channels for signal validation. |
| Conventional | Refers to radio-to-radio communications, sometimes through a base station repeater or vehicular repeater. |
| Dispatcher | An individual who has radio system management duties. |
| DPD File | DVR/VRX1000 personality file saved as file_name.dpd . |
| DPL Coded Squelch | A continuous sub-audible data signal transmitted with the carrier. See Coded Squelch. |
| DVR | Digital Vehicular Repeater. |
| DVR Mode | Determines the communication exchange capabilities between System Users and Local Portable Users; Can be set to OFF, LOCAL or SYSTEM. |
| DVRS | Digital Vehicular Repeater interfaced to a Remote Mount APX Mobile radio with or without Control Head or to a remote mount XTL2500 / XTL5000 with O3/O5/M5 Control head. |
| 'DVRS/VRX1000 Enabled' PSU | P25 XTS™1500, XTS™2500, XTS™5000, APX™4000, APX™6000 or APX™7000 Portable Radio with enabled DVRS/VRX1000 operation. |

| Keyword | Description |
|---------------------------|---|
| EPR File | File containing DVR/VRX1000 personality (dpd) and calibration data of the specific DVR/VRX1000 unit. Typically saved in the following format xxxxxxxx.epr where xxxxxxxx is the SN of the specific DVR/VRX1000. |
| FCC | Federal Communications Commission. |
| FNE | Fixed Network Equipment – Trunking or Conventional System Infrastructure |
| Forced Analog Mode | Hybrid DVR/VRX1000 Mode of operation where communications between the DVR/VRX1000 and the P25 'DVR/VRX1000 enabled' PSUs are digital while the voice communications are forced to be analog when the MSU is operating on a non-P25 channel / TG. When the MSU is operating on a P25 channel / TG, the DVR/VRX1000 is operating in Digital mode (digital voice and signaling). |
| Heart Beat | P25 Message periodically sent by a Primary DVR/VRX1000 to other DVR/VRX1000 units during Primary/Secondary processing. |
| HUB | Hang Up Box – refers to the MSU Microphone being on hook or off hook. |
| ICM | In Car Monitor – when enabled in the MSU, allows the MSU user to monitor voice traffic to and from the local PSU |
| Inbound Call | A Call transmitted by Local PSU and received by the DVR/VRX1000. |
| Local Mode | DVR Mode which provides extended portable-to-portable voice and data range by repeating Local PSU (optionally MSU) communications without keying up the Mobile radio interfaced to the DVR. Since the VRX1000 is simplex only, there is no Local repeat in 'Local Mode'. |
| Local PSU | PSU switched to the DVR/VRX1000 channel and used for communication with the DVR/VRX1000 |
| Local Tx Fallback | When enabled, the MSU reverts to local call if the MSU fails to access the system. |
| Mode | MSU / PSU - A programmed combination of operating parameters. DVR/VRX1000 – OFF, SYSTEM or LOCAL |

| Keyword | Description |
|-------------------------------|---|
| MPE | Maximum Permissible Exposure. |
| MSU | Mobile Subscriber Unit |
| NAC | Network Access Code – used in P25 mode for validation of P25 radio communications, similar to the use of PL/DPL in analog mode. Also used for DVR/VRX1000 Steering. |
| NID | Network ID - see Network Access Code (NAC) |
| Outbound Call | System Call received by the MSU. |
| PSU | Portable Subscriber Unit. |
| PTT | Push to talk. The PTT engages the transmitter (of the Portable or Mobile radio or VRX1000) when pressed. |
| RF | Radio Frequency. Part of the general frequency spectrum 10kHz - 10,000,000 MHz. |
| RSSI | Received Signal Strength Indicator. |
| System Mode | DVR/VRX1000 mode which provides extended voice and signaling communications between System Users and Local Portable Users over the selected DVR/VRX1000 channel / MSU Mode. |
| Talk Group | A group of radio users who communicate with each other by using the same communication path. |
| Talk Group Translation | Feature where the PSU talkgroup is translated by the DVR to match the currently selected MSU talkgroup. |
| Trunking | The automatic sharing of radio frequencies by large number of users based on communication path sharing for the length of a conversation. |
| Tweaker | DVR/VRX1000 Programming Software Application |

Index

A

Adaptive Power Control, 36
Analog Audio Buffering, 55
Analog Mode, 53
Automatic PSU Revert to Talk Around (TA), 43
Automatic VR Activation (AVRA), 17

B

Band Locking, 12

C

Contact Information, 65
Cross-Band, 10

D

Digital Audio Buffering, 36
Digital Mode, 45, 47
DVRs/VRX Control Mode, 23
DVRs/VRX Disabled' Mobile Radio TGs / Channels,
17
DVRs/VRX Enabled PSUs, 14
DVRs/VRX Enabled' Mobile Radio TGs / Channels,
16
Dynamic Regrouping, 36

E

Emergency in Analog Mode, 54
Emergency in Digital Mode, 40
Emergency operation during TG Translation, 41

F

Fireground (FG) Signaling, 42, 55
Forced Analog Mode, 49

G

Glossary, 68
Group Alias Update, 44
Group Services, 43
Group Text, 43

I

In Car Monitor (ICM), 24
In-Band, 11

L

Leading & Trailing Tones, 56
Legacy Mobexcom II Voting Compatibility Mode, 27
Local Mode, 22
Local Mode Indication, 34

M

Mixed VRX1000 Mode, 63
Mobile Mode Steering via PL/DPL, 57
MSU Operating on TDMA (P25, Phase 2), 57
MSU Proxy Request Priorities, 31
MSU Scan, 28

N

Network Status Reporting, 34

P

P25 Digital Mode, 30
P25 Encryption, 37
P25 Encryption in Analog Mode, 56
P25 Trunking OTAR, 34
Patch, 35
Permanent Primary Activation, 27
Permanent Primary Deactivation, 27
Phone Interconnect, 36
Primary / Secondary, 25
Private Calls, 33
PSU Affiliation, 31
PSU Call Alert, 42
PSU IV&D, 42
PSU Location Reporting 42
PSU Message, 42
PSU Proxy Request Priorities, 31
PSU Status Update and Status Request, 42
PSU Talk Permit Tones, 33

R

Radio Check / Inhibit, 34
Remote Activation of the VRX1000, 18
Remote VRX1000 Activation and Steering, 38
Remote VRX1000 Activation via DTMF, 56

S

Selecting VRX1000 Mode, 23
Status Broadcast, 34
System Mode, 21

T

Tactical Public Safety (TPS), 55

Talk Group Proxy, 32
Talk Group Translation, 32
TPS Signaling, 64

U

Unsupported PSU Features, 29

V

VRX1000 Compatibility, 9
VRX1000 Features by PSU Type, 13
VRX1000 Modes of Operation, 20
VRX1000 Status Display, 16



Futurecom Systems Group, ULC.
3277 Langstaff Rd
Concord, Ontario L4K 5P8
Canada
1-800-701-9180

© Futurecom Systems Group, ULC 2016