



Futurecom Systems Group, ULC

PDR8000 Portable Digital Repeater Deployment Guide

Document: 8K088X03
Revision: R1.0
Date: 2017-05-25

Document Revisions

Revision	Date	ECN	Notes & References
D2	2017-05-09	n/a	Trial Release
R1.0	2017-05-25	n/a	Initial Release

Proprietary Statement

© 2017 Futurecom Systems Group ULC.
Printed in Canada. All Rights Reserved

No part of this document, or any software included with it, may be reproduced and distributed without the prior written permission of the copyright holder.

Futurecom Systems Group ULC. reserves the right to make changes or improvements to the equipment, software or specification described in this document at any time and without prior notice. These changes will be incorporated in the new releases of this document.

This document may contain technical inaccuracies or typographical errors.

Futurecom Systems Group ULC. waives responsibility for any labour, materials or costs incurred by any party as a result of using this document.

MOTOROLA, MOTO, MOTOROLA SOLUTIONS and the Stylized M Logo are trademarks or registered trademarks of Motorola Trademark Holdings, LLC and are used under license. All other trademarks are the property of their respective owners.

Table of Contents

Introduction	5
Step 1- Internal Connections	7
Step 2- External Connections	8
Step 3- V.24 Connection	10
Step 4- Power	10
Step 5- Power Up Confirmation	10
Open/Closed Case Operation	11
Appendix A- V.24 Cable	12
Appendix B- DC Cable	12

List of Figures

Figure 1: Internal Duplexer Hardware Configuration.....	5
Figure 2: Simplex Hardware Configuration.....	5
Figure 3: Internal Duplexer and Booster Hardware Configuration (Future).....	6
Figure 4: External Duplexer Hardware Configuration.....	6
Figure 5: External Duplexer and Booster Hardware Configuration (Future).....	6
Figure 6: Removable Top Panel.....	7
Figure 7: Top Panel Removed.....	7
Figure 8: Side Panel Release Latch.....	8
Figure 9: Pull Release Latch.....	8
Figure 10: External Ports.....	8
Figure 11: Status Indication LEDs.....	11
Figure 12: Open Case.....	11
Figure 13: Closed Case.....	11

Introduction

The PDR8000 is typically a self-contained device, but is easily modified to utilize an alternate duplexer and/or a transmit power Booster when required. Multiple RF hardware configurations are supported, using accessible internal and external connection points to enable the desired configuration. This manual provides installation instructions for each of these configurations. The figures below are also screened on the back of the removable top panel inside the PDR8000.

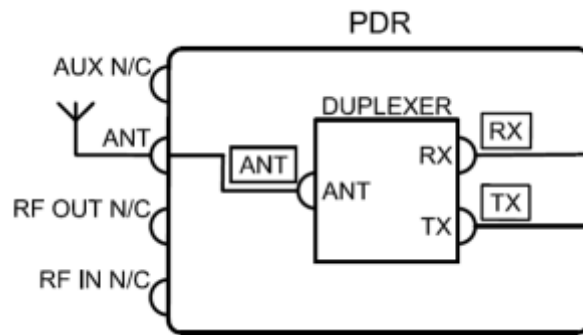

Figure 1: Internal Duplexer Hardware Configuration

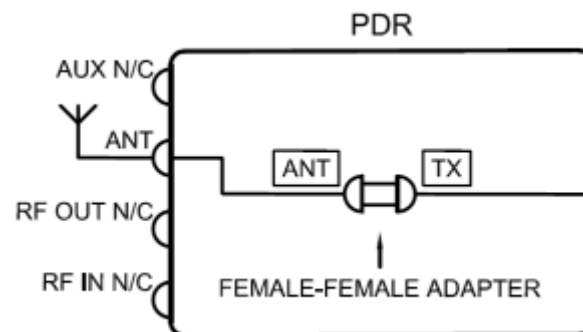

Figure 2: Simplex Hardware Configuration

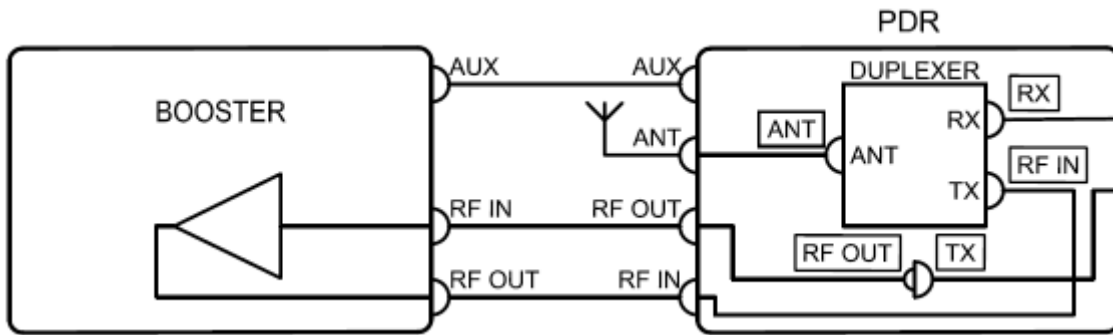

Figure 3: Internal Duplexer and Booster Hardware Configuration (Future)

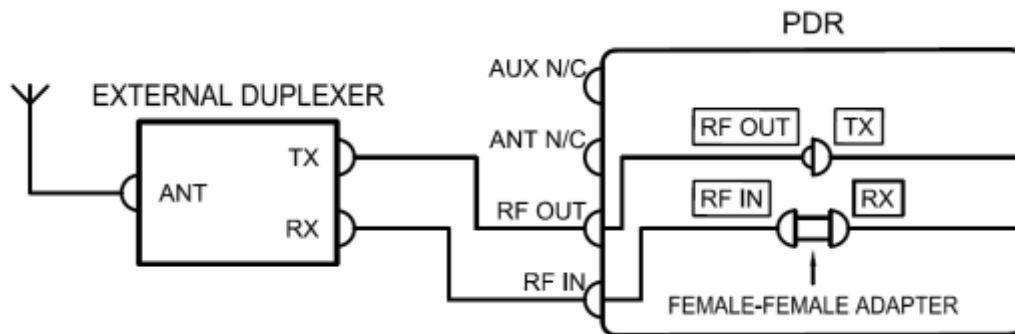

Figure 4: External Duplexer Hardware Configuration

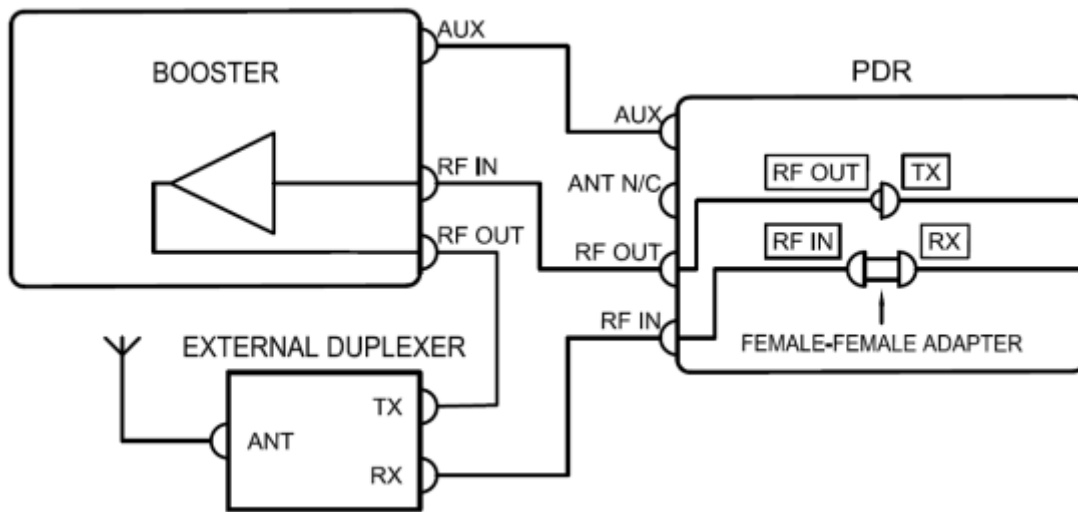

Figure 5: External Duplexer and Booster Hardware Configuration (Future)

Step 1- Internal Connections

Determine the required RF hardware configuration and confirm the internal connections correspond to the instructions below. To access the internal connections, unscrew the four corner thumbscrews of the top panel and remove it.



Figure 6: Removable Top Panel



Figure 7: Top Panel Removed

Internal Duplexer Cable Connections

- RX labelled cable is connected to RX port on Duplexer
- TX labelled cable is connected to TX port on Duplexer
- ANT labelled cable is connected to ANT port on Duplexer

Simplex Cable Connections

- TX labelled cable is connected to ANT labelled cable using the supplied Female-Female adapter

Internal Duplexer and Booster Cable Connections FUTURE

- RX labelled cable is connected to RX port on Duplexer
- RF IN labelled cable is connected to TX port on Duplexer
- ANT labelled cable is connected to ANT port on Duplexer
- TX labelled cable is connected to RF OUT labelled cable

External Duplexer Cable Connections

- TX labelled cable is connected to RF OUT labelled cable
- RX labelled cable is connected to RF IN labelled cable using the supplied Female-Female adapter

External Duplexer and Booster Cable Connections FUTURE

- TX labelled cable is connected to RF OUT labelled cable
- RX labelled cable is connected to RF IN labelled cable using the supplied Female-Female adapter

Once connections are complete, replace the top cover and screw back in place.

Step 2- External Connections

Based on the required RF hardware configuration, proceed with the external connections as per the instructions below. To access the external connections, pull the release latch and remove the side panel. When replacing the side panel, hook left side of panel in place first and then push the right side of panel in place. A click will be heard when it locks in place.



Figure 8: Side Panel Release Latch



Figure 9: Pull Release Latch



Figure 10: External Ports

1. V.24 – RJ-45 Type, 17-111574, with Dustcap
2. LAN – RJ-45 Type, 17-111574, with Dustcap (for future use)
3. DC Input – LEMO push pull, EGL.2K.302.CLA, with Dustcap
4. AC Input – powerCON TRUE1, NAC3MPX, with Sealing Cover
5. AUX – LEMO push pull, EGG.1K.306.CLL, with Dustcap
6. PDR Antenna – N female, with Dustcap
7. RF Output – N female, with Dustcap
8. RF Input – N female, with Dustcap

To access the AUX end connector, pull off the dust cap. To access the ANTENNA, RF OUT and RF IN end connectors, unscrew the dust caps.

Internal Duplexer

- ANT labelled cable is connected to ANTENNA end connector
- AUX, RF OUT, and RF IN are not connected

Simplex

- ANT labelled cable is connected to ANTENNA end connector
- AUX, RF OUT, and RF IN are not connected

Internal Duplexer and Booster FUTURE

- AUX labelled cable is connected from AUX end connector of PDR8000 to AUX end connector of Booster
- ANT labelled cable is connected to ANTENNA end connector
- RF labelled cable is connected from RF OUT end connector of PDR8000 to RF IN end connector of Booster
- RF labelled cable is connected from RF IN end connector of PDR8000 to RF OUT end connector of Booster

External Duplexer

- Duplexer cable (supplied by end user) is connected from RF OUT end connector of PDR8000 to TX end connector of External Duplexer
- Duplexer cable (supplied by end user) is connected from RF IN end connector of PDR8000 to RX end connector of External Duplexer
- AUX and ANTENNA are not connected

External Duplexer and Booster FUTURE

- AUX labelled cable is connected from AUX end connector of PDR8000 to AUX end connector of Booster
- RF labelled cable is connected from RF OUT end connector of PDR8000 to RF IN end connector of Booster
- Duplexer cable (supplied by end user) is connected from RF IN end connector of PDR8000 to RX end connector of External Duplexer
- Duplexer cable (supplied by end user) is connected from TX end connector of External Duplexer to RF OUT end connector of Booster

Step 3- V.24 Connection

To access the V.24 end connector, unscrew the dust cover. (refer to Figure 10) The V.24 cable (supplied by end user- see Appendix A) is connected from the V.24 end connector of the PDR8000 to the V.24 system device: DIU (supplied by end user), Modem (supplied by end user), Conventional Channel Gateway (supplied by end user- available as model number SQM01SUM0205 from Motorola Solutions) or another PDR8000.

NOTE: The V.24 end connector on the PDR8000 is weatherproof. To ensure connection remains weatherproof, an IP 65 compliant end connector (ie CONEC 17-103274) should be used with the V.24 cable.

Step 4- Power

ATTENTION!

Only proceed with this step once all the other connections are complete.

DC Power- to access the end connector, unscrew dust cover. (refer to Figure 10) Line up the red dots on the end connector and the cable and push DC power cable into place. Connect the other end of the DC power cable to the DC power supply. To remove the cable, pull back on the cable connector sleeve and then pull out by connector body.

AC Power- to access the end connector, pull off the dust cover. (refer to Figure 10) Insert the cable connector with the yellow release latch at the 11:00 position and twist clockwise until it locks into place at the 12:00 position. A click will be heard. Connect the other end of the AC power cable to the AC power supply. To remove the cable, pull the yellow release latch back, twist cable connector counter-clockwise and then pull the cable out.

Powering Scheme- both AC (13.8V) and DC can be connected simultaneously. The PDR8000 will dynamically choose the supply with the highest voltage and if one supply fails, the other will take over with an instant transfer of power. **NOTE:** The AC power will not charge the DC battery pack.

Step 5- Power Up Confirmation

If the PDR8000 successfully powers up, the fan will start running and the POWER LED in the bottom right corner of the LED panel will turn on.

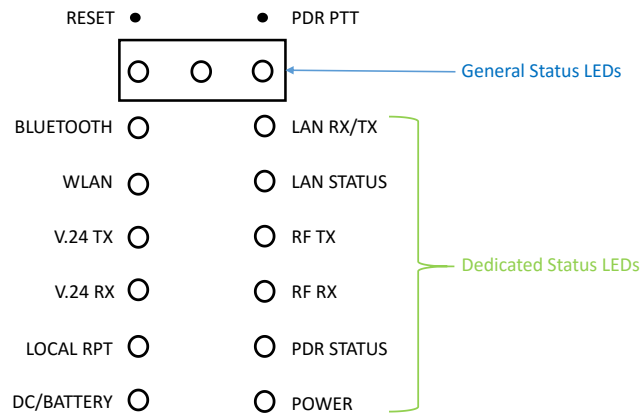

Figure 11: Status Indication LEDs

If the PDR8000 does not successfully power up, the fan will not start running and there will be no lights displayed on the LED light panel. Disconnect the power source and replace the appropriate fuse.

DC Power- the DC fuses are located inside the PDR8000. Contact Futurecom for service: 1-800-701-9180 or support@futurecom.com

AC Power- the AC fuse is located inside the Duplexer compartment. Unscrew the four screws and remove the top panel. (refer to Figure 6, Figure 7) The fuse is located in the bottom right corner. Unscrew the fuse cover counterclockwise to remove it and replace the fuse.

Open/Closed Case Operation

PDR8000 has been designed to support both open-case and closed-case operation. When operating closed-case, the PDR8000 should be standing on its hinged side, allowing the case to provide better cooling efficiency. When operating open-case (providing the best cooling capability), the PDR8000 is to be placed flat on its large surface. Note that the PDR8000 is not water resistant when operating open-case.



Figure 12: Open Case



Figure 13: Closed Case

Appendix A- V.24 Cable

The V.24 cable may be created at a custom length for each customer configuration. It consists of an RJ-45 connector used with CAT5e (minimum) cable that provides the interface to a Digital Interface Unit (DIU) or Conventional Channel Gateway (CCGW) as per the port pin-outs below.

Signal Name	Pin Number	Type
RCLK	1	Input
Rx Line Det	2	Input
TCLK	3	Input/Output
GND	4	GND
Data Rx	5	Input
Data Tx	6	Output
CTS	7	Input
RTS	8	Output

To ensure connection remains weatherproof, it is recommended to use RJ-45 connector CONEC 17-103274.

Appendix B- DC Cable

The DC cable shipped with the PDR8000 has a connector on one end and flying leads on the other. To complete the cable, connect the black wire to ground and the red cable to +13.8V.